

HAWAII ADMINISTRATIVE RULES

TITLE 12

DEPARTMENT OF LABOR AND INDUSTRIAL RELATIONS

SUBTITLE 8

DIVISION OF OCCUPATIONAL SAFETY AND HEALTH

PART 2

GENERAL INDUSTRY STANDARDS

CHAPTER 80.1

MACHINERY AND MACHINE GUARDING

§12-80.1-1 Farm field and farmstead equipment  
§12-80.1-2 Incorporation of federal standard

Historical note: Chapter 12-80.1 is based substantially upon chapter 12-80. [Eff 12/6/82; am 5/28/83; am 8/16/84; am 8/15/87; am and comp 3/22/91; am 8/10/95; R 12/29/01]

**§12-80.1-1 Farm field and farmstead equipment.** (a) This section provides for the protection of employees from the hazards associated with moving machinery parts of farm field and farmstead equipment used in any agricultural operation.

(b) This section applies to all farm field and farmstead equipment, except that subsections (j), (k), (l)(2)(A), (n), (o), and (p)(2)(A) do not apply to equipment manufactured before October 25, 1976.

(c) At the time of initial assignment and at least annually thereafter, the employer shall instruct every employee in the safe operation and servicing of all equipment to which this section applies and with which the employer is or will be involved, including at least the following safe operating practices.

- (1) All guards shall be kept in place when the machine is in operation.
- (2) There shall be no riders on farm field equipment other than persons required for instruction or assistance in machine operation.
- (3) The operator shall stop the engine, disconnect the power source, and wait for all machine movement to stop before servicing, adjusting, cleaning, or unclogging the equipment, except where the machine must be running to be properly serviced or maintained, in which case the employer shall instruct employees as to all steps and procedures which are necessary to safely service or maintain the equipment.
- (4) Everyone shall be clear of machinery before starting the engine, engaging power, or operating the machine.
- (5) Electrical power shall be locked out before performing maintenance or service on farmstead equipment.

(d) Except as otherwise provided in this section, each employer shall protect employees from coming into contact with hazards created by moving machinery parts through the:

- (1) Installation and use of a guard or shield or guarding by location; or
- (2) Use of a guardrail or fence, whenever a guard or shield or guarding by location is infeasible.

(e) Where guards are used to provide the protection required by this section, they shall be designed and located to protect against inadvertent contact with the hazard being guarded.

- (1) Unless otherwise specified, each guard and its supports shall be capable of withstanding the force that a 250-pound individual, leaning on or falling against the guard, would exert upon that guard.
- (2) Guards shall be free from burrs, sharp edges, and sharp corners, and shall be securely fastened to the equipment or building.

**(f)** A component is guarded by location during operation, maintenance, or servicing when, because of its location, no employee can inadvertently come in contact with the hazard during operation, maintenance, or servicing. Where the employer can show that any exposure to hazards results from employee contact which constitutes an isolated and unforeseeable event, the component shall also be considered guarded by location.

**(g)** Guardrails or fences shall be capable of protecting against employees inadvertently entering the hazardous area.

**(h)** Whenever a moving machinery part presents a hazard during servicing and maintenance, the engine shall be stopped, the power source disconnected, and all machine movement stopped before servicing or maintenance is performed, except where the employer can establish that:

- (1) The equipment must be running to be properly serviced or maintained;
- (2) The equipment cannot be serviced or maintained while a guard or guards otherwise required by this chapter are in place; and
- (3) The servicing or maintenance can be safely performed.

**(i)** Power take-off guarding for farm field equipment.

- (1) All power take-off shafts, including rear, mid- or side-mounted shafts, shall be guarded either by a master shield, as specified in paragraph (2) below or by other protective guarding.
- (2) All tractors shall be equipped with an agricultural tractor master shield on the rear power take-off except where removal of the tractor master shield is permitted by paragraph (3) below. The master shield shall have sufficient strength to prevent permanent deformation of the shield when a 250-pound operator mounts or dismounts the tractor using the shield as a step.
- (3) Power take-off driven equipment shall be guarded to protect against employee contact with positively driven rotating members of the power-drive system. Where power take-off driven equipment is of a design requiring removal of the tractor master shield, the equipment shall also include protection from that portion of the tractor power take-off shaft which protrudes from the tractor.
- (4) Signs shall be placed at prominent locations on tractors and power take-off driven equipment specifying that power-drive system safety shields must be kept in place.

**(j)** Other power transmission components for farm field equipment.

- (1) The mesh or nip-points of all power driven gears, belts, chains, sheaves, pulleys, sprockets, and idlers shall be guarded.
- (2) All revolving shafts, including projections such as bolts, keys, or set screws, shall be guarded, except smooth shaft ends protruding less than one-half the outside diameter of the shaft and its locking means.
- (3) Ground driven components shall be guarded in accordance with paragraphs (1) and (2) above if any employee may be exposed to them while the drives are in motion.

**(k)** Functional components for farm field equipment, such as snapping or husking rolls, straw spreaders and choppers, cutterbars, flail rotors, rotary beaters, mixing augers, feed rolls, conveying augers, or rotary tillers, and similar units, which must be exposed for proper function, shall be guarded to the fullest extent which will not substantially interfere with normal functioning of the component.

**(l)** Access to moving parts of farm field equipment.

- (1) Guards, shields, and access doors shall be in place when the equipment is in operation.
- (2) Where removal of a guard or access door will expose an employee to any component which continues to rotate after the power is disengaged, the employer shall provide, in the immediate area, a:
  - (A) Readily visible or audible warning of rotation; and
  - (B) Safety sign warning the employee to:
    - (i) Look and listen for evidence of rotation; and

- (ii) Not remove the guard or access door until all components have stopped.
- (m) Power take-off guarding for farmstead equipment.**
  - (1) All power take-off shafts, including rear, mid-, or side-mounted shafts, shall be guarded either by a master shield as provided in subsection (i)(2) above or other protective guarding.
  - (2) Power take-off driven equipment shall be guarded to protect against employee contact with positively driven rotating members of the power-drive system. Where power take-off driven equipment is of a design requiring removal of the tractor master shield, the equipment shall also include protection from that portion of the tractor power take-off shaft which protrudes from the tractor.
  - (3) Signs shall be placed at prominent locations on power take-off driven equipment specifying that power-drive system safety shields must be kept in place.
- (n) Other power transmission components for farmstead equipment.**
  - (1) The mesh or nip-points of all power driven gears, belts, chains, sheaves, pulleys, sprockets, and idlers shall be guarded.
  - (2) All revolving shafts, including projections such as bolts, keys, or set screws, shall be guarded, with the exception of:
    - (A) Smooth shafts and shaft ends (without any projecting bolts, keys, or set screws), revolving at less than 10 rpm, on feed handling equipment used on the top surface of materials in bulk storage facilities; and
    - (B) Smooth shaft ends protruding less than one-half the outside diameter of the shaft and its locking means.
- (o) Functional components for farmstead equipment.**
  - (1) Functional components, such as choppers, rotary beaters, mixing augers, feed rolls, conveying augers, grain spreaders, stirring augers, sweep augers, and feed augers, which must be exposed for proper function, shall be guarded to the fullest extent which will not substantially interfere with the normal functioning of the component.
  - (2) Sweep arm material gathering mechanisms on the top surface of materials within silo structures shall be guarded. The lower or leading edge of the guard shall be located no more than 12 inches above the material surface and no less than 6 inches in front of the leading edge of the rotating member of the gathering mechanism. The guard shall be parallel to, and extend the fullest practical length of, the material gathering mechanism.
  - (3) Exposed auger flighting on portable grain augers shall be guarded with either grating-type guards or solid-baffle style covers.
    - (A) The largest dimensions or openings in grating-type guards, through which materials are required to flow, shall be 4-3/4 inches. The area of each opening shall be no larger than 10 square inches. The opening shall be located no closer to the rotating flighting than 2-1/2 inches.
    - (B) Slotted openings in solid-baffle style covers shall be no wider than 1-1/2 inches, or closer than 3-1/2 inches to the exposed flighting.
- (p) Access to moving parts of farmstead equipment.**
  - (1) Guards, shields, and access doors shall be in place when the equipment is in operation.
  - (2) Where removal of a guard or access door will expose an employee to any component which continues to rotate after the power is disengaged, the employer shall provide, in the immediate area, a:
    - (A) Readily visible or audible warning of rotation; and
    - (B) Safety sign warning the employee to:
      - (i) Look and listen for evidence of rotation; and
      - (ii) Not remove the guard or access door until all components have stopped.
- (q) Electrical disconnect means for farmstead equipment.**
  - (1) Application of electrical power from a location not under the immediate and exclusive control of the employee or employees maintaining or servicing equipment shall be prevented by:

- (A) Providing an exclusive, positive locking means on the main switch which can be operated only by the employee or employees performing the maintenance or servicing; or
  - (B) In the case of material handling equipment located in a bulk storage structure, by physically locating on the equipment an electrical or mechanical means to disconnect the power.
- (2) All circuit protection devices, including those which are an integral part of a motor, shall be of the manual-reset type, except where:
- (A) The employer can establish that because of the nature of the operation, distances involved, and the amount of time normally spent by employees in the area of the affected equipment, use of the manual-reset device would be infeasible;
  - (B) There is an electrical disconnect switch available to the employee within 15 feet of the equipment upon which maintenance or service is being performed; and
  - (C) A sign is prominently posted near each hazardous component which warns the employee that unless the electrical disconnect switch is utilized, the motor could automatically reset while the employee is working on the hazardous component.
- [Eff 12/29/01] (Auth: HRS §396-4) (Imp: HRS §396-4)

**§12-80.1-2 Incorporation of federal standard.** Title 29, Code of Federal Regulations, Subpart O, entitled "Machinery and Machine Guarding" published by the Office of the Federal Register, National Archives and Records Administration, on June 27, 1974; and the amendments published on December 3, 1974; January 27, 1975; October 24, 1978; November 7, 1978; February 8, 1980; February 10, 1984; April 30, 1984; July 7, 1986; September 29, 1986; March 14, 1988; February 13, 1996; and March 7, 1996, are made a part of this chapter, except as provided in section 12-80.1-1. [Eff 12/29/01] (Auth: HRS §396-4) (Imp: HRS §396-4)

**§1910.211 Definitions.**

- (a) As used in §§1910.213 and 1910.214 unless the context clearly requires otherwise, the following woodworking machinery terms shall have the meaning prescribed in this paragraph.
- (1) **Point of operations** means that point at which cutting, shaping, boring, or forming is accomplished upon the stock.
  - (2) **Push stick** means a narrow strip of wood or other soft material with a notch cut into one end and which is used to push short pieces of material through saws.
  - (3) **Block** means a short block of wood, provided with a handle similar to that of a plane and a shoulder at the rear end, which is used for pushing short stock over revolving cutters.
- (b) As used in §1910.215 unless the context clearly requires otherwise, the following abrasive wheel machinery terms shall have the meanings prescribed in this paragraph.
- (1) **Type 1 straight wheels** means wheels having diameter, thickness, and hole size dimensions, and they should be used only on the periphery. Type 1 wheels shall be mounted between flanges.

LIMITATION: Hole dimension (H) should not be greater than two-thirds of wheel diameter dimension (D) for precision, cylindrical, centerless, or surface grinding applications. Maximum hole size for all other applications should not exceed one-half wheel diameter.

## FIGURE NO. 0-1.—TYPE 1 STRAIGHT WHEELS

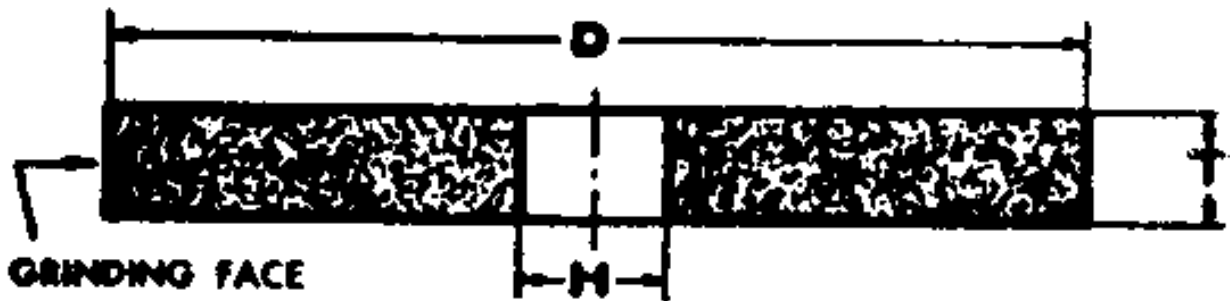

### Type 1—Straight Wheel.

Peripheral grinding wheel having a diameter, thickness and hole.

- (2) **Type 2 cylinder wheels** means wheels having diameter, wheel thickness, and rim thickness dimensions. Grinding is performed on the rim face only, dimension  $W$ . Cylinder wheels may be plain, plate mounted, inserted nut, or of the projecting stud type.

LIMITATION: Rim height,  $T$  dimension, is generally equal to or greater than rim thickness,  $W$  dimension.

## FIGURE NO. 0-2.—TYPE 2 CYLINDER WHEELS

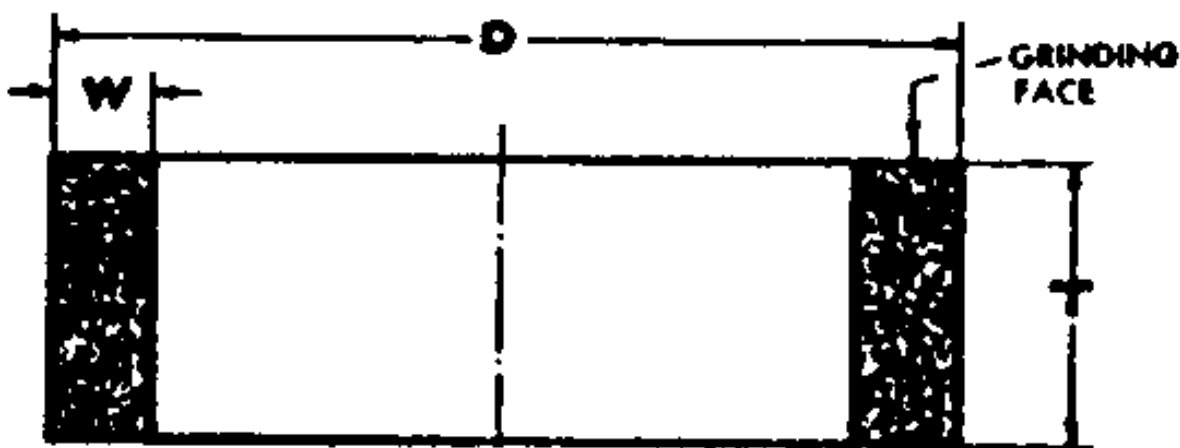

Type 2—Cylinder Wheel

Side grinding wheel having a diameter, thickness and wall--wheel is mounted on the diameter.

- (3) **Type 6 straight cup wheels** means wheels having diameter, thickness, hole size, rim thickness, and back thickness dimensions. Grinding is always performed on rim face, W dimension.

LIMITATION: Minimum back thickness, E dimension, should not be less than one-fourth T dimension. In addition, when unthreaded hole wheels are specified, the inside flat, K dimension, must be large enough to accommodate a suitable flange.

## FIGURE NO. 0-3.—TYPE 6 STRAIGHT CUP WHEELS

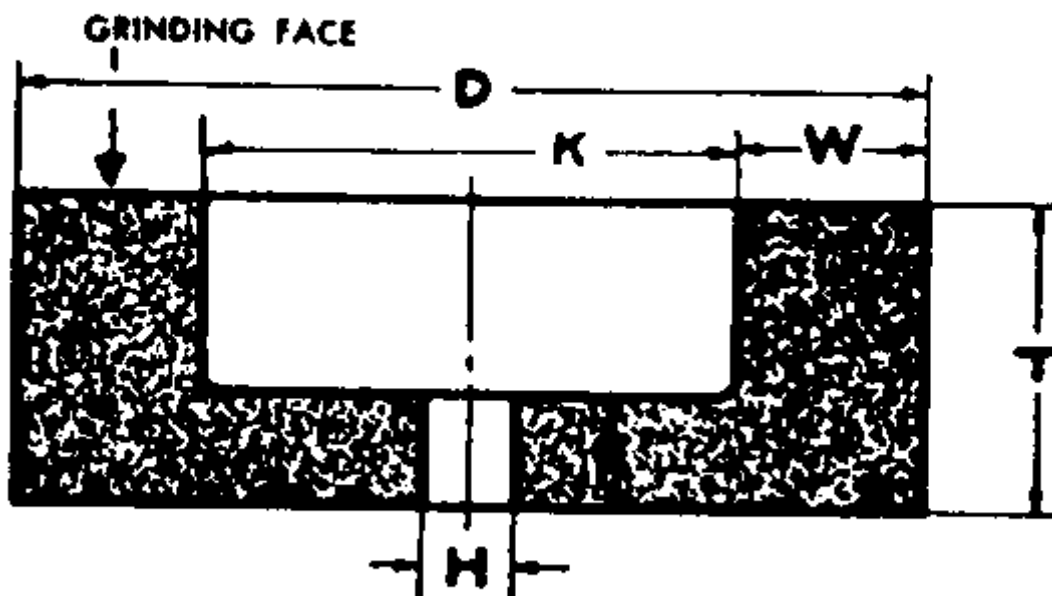

**Type 6—Straight-cup Wheel**

Side grinding wheel having a diameter, thickness and hole with one side straight or flat and the opposite side recessed. This type, however, differs from Type 5 in that the grinding is performed on the wall of the abrasive created by the difference between the diameter of the recess and the outside diameter of the wheel. Therefore, the wall dimension "W" takes precedence over the diameter of the recess as an essential intermediate dimension to describe this shape type.

- (4) **Type 11 flaring cup wheels** mean wheels having double diameter dimensions D and J, and in addition have thickness, hole size, rim and back thickness dimensions. Grinding is always performed on rim face, W dimension. Type 11 wheels are subject to all limitations of use and mounting listed for type 6 straight sided cup wheels definition.

LIMITATION: Minimum back thickness, E dimension, should not be less than one-fourth T dimension. In addition when unthreaded hole wheels are specified the inside flat, K dimension, shall be large enough to accommodate a suitable flange.

## FIGURE NO. 0-4.—TYPE 11 FLARING CUP WHEELS

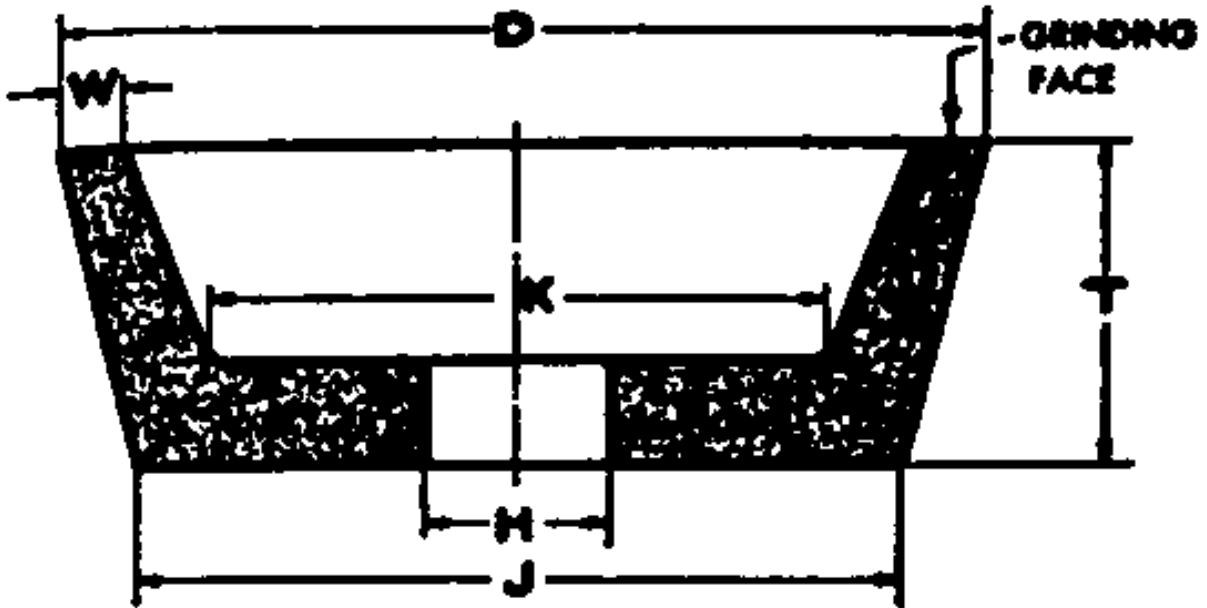

**Type 11—Flaring-cup Wheel**

Side grinding wheel having a wall flared or tapered outward from the back. Wall thickness at the back is normally greater than at the grinding face (*W*).

- (5) **Modified types 6 and 11 wheels (terrazzo)** mean some type 6 and 11 cup wheels used in the terrazzo trade having tapered *K* dimensions to match a special tapered flange furnished by the machine builder.

LIMITATION: These wheels shall be mounted only with a special tapered flange.

## FIGURE NO. 0-5

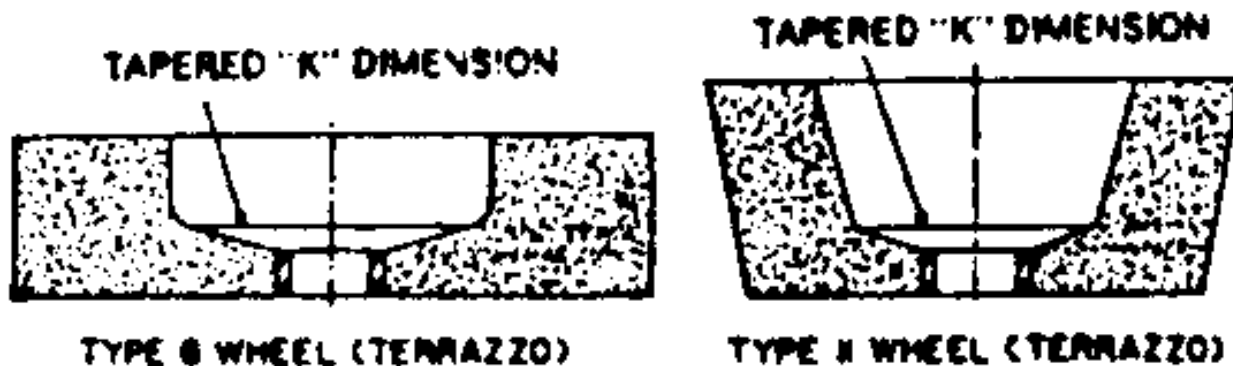

Typical examples of modified types 6 and 11 wheels (terrazzo) showing tapered K dimensions.

- (6) **Types 27 and 28 depressed center wheels** mean wheels having diameter, thickness, and hole size dimensions. Both types are reinforced, organic bonded wheels having offset hubs which permit side and peripheral grinding operations without interference with the mounting. Type 27 wheels are manufactured with flat grinding rims permitting notching and cutting operations. Type 28 wheels have saucer shaped grinding rims.
- (i) Limitations: Special supporting, back adapter and inside flange nuts are required for the proper mounting of these types of wheels subject to limitations of §1910.215(c)(4)(i) and (ii).
  - (ii) Mounts which are affixed to the wheel by the manufacturer may not require an inside nut and shall not be reused.
- (7) **Type 27A depressed center, cutting-off wheels** mean wheels having diameter, thickness, and hole size dimensions. They are reinforced, organic bonded, offset hub type wheels, usually 16 inches diameter and larger, specially designed for use on cutting-off machines where mounting nut or outer flange interference cannot be tolerated.

LIMITATIONS: See §1910.215(c)(1).

- (8) **Surface feet per minute (s.f.p.m.)** means the distance in feet any one abrasive grain on the peripheral surface of a grinding wheel travels in 1 minute.

Surface Feet Per Minute =  $3.1416 \times \text{diameter in inches} \times \text{r.p.m.} \div 12$  or  
 $0.262 \times \text{diameter in inches} \times \text{r.p.m.}$

Examples: (a) 24-inch diameter wheel, 1,000 revolutions per minute. Surface Feet per minute  
 $0.262 \times 24 \times 1,000 = 6,288$  s.f.p.m.

(b) 12-inch diameter wheel, 1,000 revolutions per minute. Surface Feet per minute  
 $.262 \times 12 \times 1,000 = 3,144$  s.f.p.m.

- (9) **Flanges** means collars, discs or plates between which wheels are mounted and are referred to as adaptor, sleeve, or back up type. See paragraph (c) of §1910.215 for full description.
- (10) **Snagging** means grinding which removes relatively large amounts of material without regard to close tolerances or surface finish requirements.

- (11) **Off-hand grinding** means the grinding of any material or part which is held in the operator's hand.
- (12) **Safety guard** means an enclosure designed to restrain the pieces of the grinding wheel and furnish all possible protection in the event that the wheel is broken in operation. See paragraph (b) of §1910.215.
- (13) **Cutting off wheels** means wheels having diameter thickness and hole size dimensions and are subject to all limitations of mounting and use listed for type 1 wheels, the definition in subparagraph (1) of this paragraph and paragraph (d) of §1910.215. They may be steel centered, diamond abrasive or organic bonded abrasive of the plain or reinforced type.
  - (i) Limitation: Cutting off wheels are recommended only for use on specially designed and fully guarded machines and are subject to the following maximum thickness and hole size limitations.

| Wheel diameter                           | Max. thickness (inch) |
|------------------------------------------|-----------------------|
| 6 inch and smaller .....                 | 3/18                  |
| Larger than 6 inches to 12 inches .....  | 1/4                   |
| Larger than 12 inches to 23 inches ..... | 3/8                   |
| Larger than 23 inches.....               | 1/2                   |

- (ii) Maximum hole size for cutting-off wheels should not be larger than 1/4-wheel diameter.
- (14) **Abrasive wheel** means a cutting tool consisting of abrasive grains held together by organic or inorganic bonds. Diamond and reinforced wheels are included.
- (15) **Organic wheels** means wheels which are bonded by means of an organic material such as resin, rubber, shellac, or other similar bonding agent.
- (16) **Inorganic wheels** means wheels which are bonded by means of inorganic material such as clay, glass, porcelain, sodium silicate, magnesium oxychloride, or metal. Wheels bonded with clay, glass, porcelain or related ceramic materials are characterized as **vitrified bonded wheels**.
- (c) As used in §1910.216, unless the context clearly requires otherwise, the following mills and calenders in the rubber and plastic industries terms shall have the meanings prescribed in this paragraph.
  - (1) **Bite** means the nip point between any two inrunning rolls.
  - (2) **Calender** means a machine equipped with two or more metal rolls revolving in opposite directions and used for continuously sheeting or plying up rubber and plastics compounds and for frictioning or coating materials with rubber and plastics compounds.
  - (3) **Mill** means a machine consisting of two adjacent metal rolls, set horizontally, which revolve in opposite directions (i.e., toward each other as viewed from above) used for the mechanical working of rubber and plastics compounds.
- (d) As used in §1910.217, unless the context clearly requires otherwise, the following power press terms shall have the meaning prescribed in this paragraph.
  - (1) **Antirepeat** means the part of the clutch/brake control system designed to limit the press to a single stroke if the tripping means is held operated. Antirepeat requires release of all tripping mechanisms before another stroke can be initiated. **Antirepeat** is also called single stroke reset or reset circuit.
  - (2) **Brake** means the mechanism used on a mechanical power press to stop and/or hold the crankshaft, either directly or through a gear train, when the clutch is disengaged.
  - (3) **Bolster plate** means the plate attached to the top of the bed of the press having drilled holes or T-slots for attaching the lower die or die shoe.
  - (4) **Clutch** means the coupling mechanism used on a mechanical power press to couple the flywheel to the crankshaft, either directly or through a gear train.
  - (5) **Full revolution clutch** means a type of clutch that, when tripped, cannot be disengaged until the crankshaft has completed a full revolution and the press slide a full stroke.

- (6) **Part revolution clutch** means a type of clutch that can be disengaged at any point before the crankshaft has completed a full revolution and the press slide a full stroke.
- (7) **Direct drive** means the type of driving arrangement wherein no clutch is used; coupling and decoupling of the driving torque is accomplished by energization and deenergization of a motor. Even though not employing a clutch, direct drives match the operational characteristics of "part revolution clutches" because the driving power may be disengaged during the stroke of the press.
- (8) **Concurrent** means acting in conjunction, and is used to describe a situation wherein two or more controls exist in an operated condition at the same time.
- (9) **Continuous** means uninterrupted multiple strokes of the slide without intervening stops (or other clutch control action) at the end of individual strokes.
- (10) **Counterbalance** means the mechanism that is used to balance or support the weight of the connecting rods, slide, and slide attachments.
- (11) **Device** means a press control or attachment that:
  - (i) Restrains the operator from inadvertently reaching into the point of operation, or
  - (ii) Prevents normal press operation if the operator's hands are inadvertently within the point of operation, or
  - (iii) Automatically withdraws the operator's hands if the operator's hands are inadvertently within the point of operation as the dies close, or
  - (iv) Prevents the initiation of a stroke, or stops of stroke in progress, when there is an intrusion through the sensing field by any part of the operator's body or by any other object.
- (12) **Presence sensing device** means a device designed, constructed and arranged to create a sensing field or area that signals the clutch/brake control to deactivate the clutch and activate the brake of the press when any part of the operator's body or a hand tool is within such field or area.
- (13) **Gate or movable barrier device** means a movable barrier arranged to enclose the point of operation before the press stroke can be started.
- (14) **Holdout or restraint device** means a mechanism, including attachments for operator's hands, that when anchored and adjusted prevent the operator's hands from entering the point of operation.
- (15) **Pull-out device** means a mechanism attached to the operator's hands and connected to the upper die or slide of the press, that is designed, when properly adjusted, to withdraw the operator's hands as the dies close, if the operator's hands are inadvertently within the point of operation.
- (16) **Sweep device** means a single or double arm (rod) attached to the upper die or slide of the press and designed to move the operator's hands to a safe position as the dies close, if the operator's hands are inadvertently within the point of operation.
- (17) **Two hand control device** means a two hand trip that further requires concurrent pressure from both hands of the operator during a substantial part of the die-closing portion of the stroke of the press.
- (18) **Die** means the tooling used in a press for cutting or forming material. An upper and a lower die make a complete set.
- (19) **Die builder** means any person who builds dies for power presses.
- (20) **Die set** means a tool holder held in alignment by guide posts and bushings and consisting of a lower shoe, an upper shoe or punch holder, and guide posts and bushings.
- (21) **Die setter** means an individual who places or removes dies in or from mechanical power presses, and who, as a part of his duties, makes the necessary adjustments to cause the tooling to function properly and safely.
- (22) **Die setting** means the process of placing or removing dies in or from a mechanical power press, and the process of adjusting the dies, other tooling and safeguarding means to cause them to function properly and safely.
- (23) **Die shoe** means a plate or block upon which a die holder is mounted. A die shoe functions primarily as a base for the complete die assembly, and, when used, is bolted or clamped to the bolster plate or the face of slide.
- (24) **Ejector** means a mechanism for removing work or material from between the dies.

- (25) **Face of slide** means the bottom surface of the slide to which the punch or upper die is generally attached.
- (26) **Feeding** means the process of placing or removing material within or from the point of operation.
- (27) **Automatic feeding** means feeding wherein the material or part being processed is placed within or removed from the point of operation by a method or means not requiring action by an operator on each stroke of the press.
- (28) **Semiautomatic feeding** means feeding wherein the material or part being processed is placed within or removed from the point of operation by an auxiliary means controlled by operator on each stroke of the press.
- (29) **Manual feeding** means feeding wherein the material or part being processed is handled by the operator on each stroke of the press.
- (30) **Foot control** means the foot operated control mechanism designed to be used with a clutch or clutch/brake control system.
- (31) **Foot pedal** means the foot operated lever designed to operate the mechanical linkage that trips a full revolution clutch.
- (32) **Guard** means a barrier that prevents entry of the operator's hands or fingers into the point of operation.
- (33) **Die enclosure guard** means an enclosure attached to the die shoe or stripper, or both, in a fixed position.
- (34) **Fixed barrier guard** means a die space barrier attached to the press frame.
- (35) **Interlocked press barrier guard** means a barrier attached to the press frame and interlocked so that the press stroke cannot be started normally unless the guard itself, or its hinged or movable sections, enclose the point of operation.
- (36) **Adjustable barrier guard** means a barrier requiring adjustment for each job or die setup.
- (37) **Guide post** means the pin attached to the upper or lower die shoe operating within the bushing on the opposing die shoe, to maintain the alignment of the upper and lower dies.
- (38) **Hand feeding tool** means any hand held tool designed for placing or removing material or parts to be processed within or from the point of operation.
- (39) **Inch** means an intermittent motion imparted to the slide (on machines using part revolution clutches) by momentary operation of the **Inch** operating means. Operation of the **Inch** operating means engages the driving clutch so that a small portion of one stroke or indefinite stroking can occur, depending upon the length of time the **Inch** operating means is held operated. **Inch** is a function used by the die setter for setup of dies and tooling, but is not intended for use during production operations by the operator.
- (40) **Jog** means an intermittent motion imparted to the slide by momentary operation of the drive motor, after the clutch is engaged with the flywheel at rest.
- (41) **Knockout** means a mechanism for releasing material from either die.
- (42) **Liftout** means the mechanism also known as knockout.
- (43) **Operator's station** means the complete complement of controls used by or available to an operator on a given operation for stroking the press.
- (44) **Pinch point** means any point other than the point of operation at which it is possible for a part of the body to be caught between the moving parts of a press or auxiliary equipment, or between moving and stationary parts of a press or auxiliary equipment or between the material and moving part or parts of the press or auxiliary equipment.
- (45) **Point of operation** means the area of the press where material is actually positioned and work is being performed during any process such as shearing, punching, forming, or assembling.
- (46) **Press** means a mechanically powered machine that shears, punches, forms or assembles metal or other material by means of cutting, shaping, or combination dies attached to slides. A press consists of a stationary bed or anvil, and a slide (or slides) having a controlled reciprocating motion toward and away from the bed surface, the slide being guided in a definite path by the frame of the press.
- (47) **Repeat** means an unintended or unexpected successive stroke of the press resulting from a malfunction.
- (48) **Safety block** means a prop that, when inserted between the upper and lower dies or between the bolster plate and the face of the slide, prevents the slide from falling of its own deadweight.

- (49) **Single stroke** means one complete stroke of the slide, usually initiated from a full open (or up) position, followed by closing (or down), and then a return to the full open position.
- (50) **Single stroke mechanism** means an arrangement used on a full revolution clutch to limit the travel of the slide to one complete stroke at each engagement of the clutch.
- (51) **Slide** means the main reciprocating press member. A slide is also called a ram, plunger, or platen.
- (52) **Stop control** means an operator control designed to immediately deactivate the clutch control and activate the brake to stop slide motion.
- (53) **Stripper** means a mechanism or die part for removing the parts or material from the punch.
- (54) **Stroking selector** means the part of the clutch/brake control that determines the type of stroking when the operating means is actuated. The stroking selector generally includes positions for "Off" (Clutch Control), "Inch," "Single Stroke," and "Continuous" (when Continuous is furnished).
- (55) **Trip or (tripping)** means activation of the clutch to "run" the press.
- (56) **Turnover bar** means a bar used in die setting to manually turn the crankshaft of the press.
- (57) **Two-hand trip** means a clutch actuating means requiring the concurrent use of both hands of the operator to trip the press.
- (58) **Unitized tooling** means a type of die in which the upper and lower members are incorporated into a self contained unit so arranged as to hold the die members in alignment.
- (59) **Control system** means sensors, manual input and mode selection elements, interlocking and decision-making circuitry, and output elements to the press operating mechanism.
- (60) **Brake monitor** means a sensor designed, constructed, and arranged to monitor the effectiveness of the press braking system.
- (61) **Presence sensing device initiation** means an operating mode of indirect manual initiation of a single stroke by a presence sensing device when it senses that work motions of the operator, related to feeding and/or removing parts, are completed and all parts of the operator's body or hand tools are safely clear of the point of operation.
- (62) **Safety system** means the integrated total system, including the pertinent elements of the press, the controls, the safeguarding and any required supplemental safeguarding, and their interfaces with the operator, and the environment, designed, constructed and arranged to operate together as a unit, such that a single failure or single operating error will not cause injury to personnel due to point of operation hazards.
- (63) **Authorized person** means one to whom the authority and responsibility to perform a specific assignment has been given by the employer.
- (64) **Certification** or **certify** means, in the case of design certification/validation, that the manufacturer has reviewed and tested the design and manufacture, and in the case of installation certification/validation and annual recertification/revalidation, that the employer has reviewed and tested the installation, and concludes in both cases that the requirements of §1910.217 (a) through (h) and appendix A have been met. The certifications are made to the validation organization.
- (65) **Validation** or **validate** means for PSDI safety systems that an OSHA recognized third-party validation organization:
- (i) For design certification/validation has reviewed the manufacturer's certification that the PSDI safety system meets the requirements of §1910.217 (a) through (h) and appendix A and the underlying tests and analyses performed by the manufacturer, has performed additional tests and analyses which may be required by §1910.217 (a) through (h) and appendix A, and concludes that the requirements of §1910.217 (a) through (h) and appendix A have been met; and
  - (ii) For installation certification/validation and annual recertification/revalidation has reviewed the employer's certification that the PSDI safety system meets the requirements of §1910.217 (a) through (h) and appendix A and the underlying tests performed by the employer, has performed additional tests and analyses which may be required by §1910.217 (a) through (h) and appendix A, and concludes that the requirements of §1910.217 (a) through (h) and appendix A have been met.
- (66) **Certification/validation** and **certify/validate** means the combined process of certification and validation.

- (e) As used in §1910.218, unless the context clearly requires otherwise, the following forging and hot metal terms shall have the meaning prescribed in this paragraph.
- (1) **Forging** means the product of work on metal formed to a desired shape by impact or pressure in hammers, forging machines (upsetters), presses, rolls, and related forming equipment. Forging hammers, counterblow equipment and high-energy-rate forging machines impart impact to the workpiece, while most other types of forging equipment impart squeeze pressure in shaping the stock. Some metals can be forged at room temperature, but the majority of metals are made more plastic for forging by heating.
  - (2) **Open framehammers (or blacksmith hammers)** mean hammers used primarily for the shaping of forgings by means of impact with flat dies. Open frame hammers generally are so constructed that the anvil assembly is separate from the operating mechanism and machine supports; it rests on its own independent foundation. Certain exceptions are forging hammers made with frame mounted on the anvil; e.g., the smaller, single-frame hammers are usually made with the anvil and frame in one piece.
  - (3) **Steam hammers** mean a type of drop hammer where the ram is raised for each stroke by a double-action steam cylinder and the energy delivered to the workpiece is supplied by the velocity and weight of the ram and attached upper die driven downward by steam pressure. Energy delivered during each stroke may be varied.
  - (4) **Gravity hammers** mean a class of forging hammer wherein energy for forging is obtained by the mass and velocity of a freely falling ram and the attached upper die. Examples: board hammers and air-lift hammers.
  - (5) **Forging presses** mean a class of forging equipment wherein the shaping of metal between dies is performed by mechanical or hydraulic pressure, and usually is accomplished with a single workstroke of the press for each die station.
  - (6) **Trimming presses** mean a class of auxiliary forging equipment which removes flash or excess metal from a forging. This trimming operation can also be done cold, as can coining, a product sizing operation.
  - (7) **High-energy-rate forging machines** mean a class of forging equipment wherein high ram velocities resulting from the sudden release of a compressed gas against a free piston impart impact to the workpiece.
  - (8) **Forging rolls** mean a class of auxiliary forging equipment wherein stock is shaped between power driven rolls bearing contoured dies. Usually used for preforming, roll forging is often employed to reduce thickness and increase length of stock.
  - (9) **Ring rolls** mean a class for forging equipment used for shaping weldless rings from pierced discs or thick-walled, ring-shaped blanks between rolls which control wall thickness, ring diameter, height and contour.
  - (10) **Bolt-headers** mean the same as an upsetter or forging machine except that the diameter of stock fed into the machine is much smaller, i.e., commonly three-fourths inch or less.
  - (11) **Rivet making machines** mean the same as upsetters and boltheaders when producing rivets with stock diameter of 1-inch or more. Rivet making with less than 1-inch diameter is usually a cold forging operation, and therefore not included in this subpart.
  - (12) Upsetters (or forging machines, or headers) type of forging equipment, related to the mechanical press, in which the main forming energy is applied horizontally to the workpiece which is gripped and held by prior action of the dies.
- (f) As used in §1910.219, unless the context clearly requires otherwise, the following mechanical power-transmission guarding terms shall have the meaning prescribed in this paragraph.
- (1) **Belts** include all power transmission belts, such as flat belts, round belts, V-belts, etc., unless otherwise specified.
  - (2) **Belt shifter** means a device for mechanically shifting belts from tight to loose pulleys or vice versa, or for shifting belts on cones of speed pulleys.
  - (3) **Belt pole** (sometimes called a **belt shipper** or **shipper pole**,) means a device used in shifting belts on and off fixed pulleys on line or countershaft where there are no loose pulleys.
  - (4) **Exposed to contact** means that the location of an object is such that a person is likely to come into contact with it and be injured.
  - (5) **Flywheels** include flywheels, balance wheels, and flywheel pulleys mounted and revolving on crankshaft of engine or other shafting.

- (6) **Maintenance runway** means any permanent runway or platform used for oiling, maintenance, running adjustment, or repair work, but not for passageway.
- (7) **Nip-point belt and pulley guard** means a device which encloses the pulley and is provided with rounded or rolled edge slots through which the belt passes.
- (8) **Point of operation** means that point at which cutting, shaping, or forming is accomplished upon the stock and shall include such other points as may offer a hazard to the operator in inserting or manipulating the stock in the operation of the machine.
- (9) **Prime movers** include steam, gas, oil, and air engines, motors, steam and hydraulic turbines, and other equipment used as a source of power.
- (10) **Sheaves** mean grooved pulleys, and shall be so classified unless used as flywheels.

#### §1910.212 General requirements for all machines.

- (a) Machine guarding.
  - (1) Types of guarding. One or more methods of machine guarding shall be provided to protect the operator and other employees in the machine area from hazards such as those created by point of operation, ingoing nip points, rotating parts, flying chips and sparks. Examples of guarding methods are-barrier guards, two-hand tripping devices, electronic safety devices, etc.
  - (2) General requirements for machine guards. Guards shall be affixed to the machine where possible and secured elsewhere if for any reason attachment to the machine is not possible. The guard shall be such that it does not offer an accident hazard in itself.
  - (3) Point of operation guarding.
    - (i) Point of operation is the area on a machine where work is actually performed upon the material being processed.
    - (ii) The point of operation of machines whose operation exposes an employee to injury, shall be guarded. The guarding device shall be in conformity with any appropriate standards therefor, or, in the absence of applicable specific standards, shall be so designed and constructed as to prevent the operator from having any part of his body in the danger zone during the operating cycle.
    - (iii) Special handtools for placing and removing material shall be such as to permit easy handling of material without the operator placing a hand in the danger zone. Such tools shall not be in lieu of other guarding required by this section, but can only be used to supplement protection provided.
    - (iv) The following are some of the machines which usually require point of operation guarding:
      - (a) Guillotine cutters.
      - (b) Shears.
      - (c) Alligator shears.
      - (d) Power presses.
      - (e) Milling machines.
      - (f) Power saws.
      - (g) Jointers.
      - (h) Portable power tools.
      - (i) Forming rolls and calenders.
  - (4) Barrels, containers, and drums. Revolving drums, barrels, and containers shall be guarded by an enclosure which is interlocked with the drive mechanism, so that the barrel, drum, or container cannot revolve unless the guard enclosure is in place.
  - (5) Exposure of blades. When the periphery of the blades of a fan is less than seven (7) feet above the floor or working level, the blades shall be guarded. The guard shall have openings no larger than one-half (1/2) inch.
- (b) Anchoring fixed machinery. Machines designed for a fixed location shall be securely anchored to prevent walking or moving.

#### §1910.213 Woodworking machinery requirements.

- (a) Machine construction general.
  - (1) Each machine shall be so constructed as to be free from sensible vibration when the largest size tool is mounted and run idle at full speed.

- (2) Arbors and mandrels shall be constructed so as to have firm and secure bearing and be free from play.
  - (3) [Reserved]
  - (4) Any automatic cutoff saw that strokes continuously without the operator being able to control each stroke shall not be used.
  - (5) Saw frames or tables shall be constructed with lugs cast on the frame or with an equivalent means to limit the size of the saw blade that can be mounted, so as to avoid overspeed caused by mounting a saw larger than intended.
  - (6) Circular saw fences shall be so constructed that they can be firmly secured to the table or table assembly without changing their alignment with the saw. For saws with tilting tables or tilting arbors the fence shall be so constructed that it will remain in a line parallel with the saw, regardless of the angle of the saw with the table.
  - (7) Circular saw gages shall be so constructed as to slide in grooves or tracks that are accurately machined, to insure exact alignment with the saw for all positions of the guide.
  - (8) Hinged saw tables shall be so constructed that the table can be firmly secured in any position and in true alignment with the saw.
  - (9) All belts, pulleys, gears, shafts, and moving parts shall be guarded in accordance with the specific requirements of §1910.219.
  - (10) It is recommended that each power-driven woodworking machine be provided with a disconnect switch that can be locked in the off position.
  - (11) The frames and all exposed, noncurrent-carrying metal parts of portable electric woodworking machinery operated at more than 90 volts to ground shall be grounded and other portable motors driving electric tools which are held in the hand while being operated shall be grounded if they operate at more than 90 volts to ground. The ground shall be provided through use of a separate ground wire and polarized plug and receptacle.
  - (12) For all circular saws where conditions are such that there is a possibility of contact with the portion of the saw either beneath or behind the table, that portion of the saw shall be covered with an exhaust hood, or, if no exhaust system is required, with a guard that shall be so arranged as to prevent accidental contact with the saw.
  - (13) Revolving double arbor saws shall be fully guarded in accordance with all the requirements for circular crosscut saws or with all the requirements for circular ripsaws, according to the kind of saws mounted on the arbors.
  - (14) No saw, cutter head, or tool collar shall be placed or mounted on a machine arbor unless the tool has been accurately machined to size and shape to fit the arbor.
  - (15) Combs (featherboards) or suitable jigs shall be provided at the workplace for use when a standard guard cannot be used, as in dadoing, grooving, jointing, moulding, and rabbeting.
- (b) Machine controls and equipment.**
- (1) A mechanical or electrical power control shall be provided on each machine to make it possible for the operator to cut off the power from each machine without leaving his position at the point of operation.
  - (2) On machines driven by belts and shafting, a locking-type belt shifter or an equivalent positive device shall be used.
  - (3) On applications where injury to the operator might result if motors were to restart after power failures, provision shall be made to prevent machines from automatically restarting upon restoration of power.
  - (4) Power controls and operating controls should be located within easy reach of the operator while he is at his regular work location, making it unnecessary for him to reach over the cutter to make adjustments. This does not apply to constant pressure controls used only for setup purposes.
  - (5) On each machine operated by electric motors, positive means shall be provided for rendering such controls or devices inoperative while repairs or adjustments are being made to the machines they control.
  - (6) Each operating treadle shall be protected against unexpected or accidental tripping.
  - (7) Feeder attachments shall have the feed rolls or other moving parts so covered or guarded as to protect the operator from hazardous points.
- (c) Hand-fed ripsaws.**

- (1) Each circular hand-fed rip saw shall be guarded by a hood which shall completely enclose that portion of the saw above the table and that portion of the saw above the material being cut. The hood and mounting shall be arranged so that the hood will automatically adjust itself to the thickness of and remain in contact with the material being cut but it shall not offer any considerable resistance to insertion of material to saw or to passage of the material being sawed. The hood shall be made of adequate strength to resist blows and strains incidental to reasonable operation, adjusting, and handling, and shall be so designed as to protect the operator from flying splinters and broken saw teeth. It shall be made of material that is soft enough so that it will be unlikely to cause tooth breakage. The hood shall be so mounted as to insure that its operation will be positive, reliable, and in true alignment with the saw; and the mounting shall be adequate in strength to resist any reasonable side thrust or other force tending to throw it out of line.
  - (2) Each hand-fed circular rip saw shall be furnished with a spreader to prevent material from squeezing the saw or being thrown back on the operator. The spreader shall be made of hard tempered steel, or its equivalent, and shall be thinner than the saw kerf. It shall be of sufficient width to provide adequate stiffness or rigidity to resist any reasonable side thrust or blow tending to bend or throw it out of position. The spreader shall be attached so that it will remain in true alignment with the saw even when either the saw or table is tilted. The provision of a spreader in connection with grooving, dadoing, or rabbeting is not required. On the completion of such operations, the spreader shall be immediately replaced.
  - (3) Each hand-fed circular rip saw shall be provided with nonkickback fingers or dogs so located as to oppose the thrust or tendency of the saw to pick up the material or to throw it back toward the operator. They shall be designed to provide adequate holding power for all the thicknesses of materials being cut.
- (d) Hand-fed crosscut table saws.**
- (1) Each circular crosscut table saw shall be guarded by a hood which shall meet all the requirements of paragraph (c)(1) of this section for hoods for circular rip saws.
  - (2) [Reserved]
- (e) Circular resaws.**
- (1) Each circular resaw shall be guarded by a hood or shield of metal above the saw. This hood or shield shall be so designed as to guard against danger from flying splinters or broken saw teeth.
  - (2) Each circular resaw (other than self-feed saws with a roller or wheel at back of the saw) shall be provided with a spreader fastened securely behind the saw. The spreader shall be slightly thinner than the saw kerf and slightly thicker than the saw disk.
- (f) Self-feed circular saws.**
- (1) Feed rolls and saws shall be protected by a hood or guard to prevent the hands of the operator from coming in contact with the in-running rolls at any point. The guard shall be constructed of heavy material, preferably metal, and the bottom of the guard shall come down to within three-eighths inch of the plane formed by the bottom or working surfaces of the feed rolls. This distance (three-eighths inch) may be increased to three-fourths inch, provided the lead edge of the hood is extended to be not less than 5 1/2 inches in front of the nip point between the front roll and the work.
  - (2) Each self-feed circular rip saw shall be provided with sectional non-kickback fingers for the full width of the feed rolls. They shall be located in front of the saw and so arranged as to be in continual contact with the wood being fed.
- (g) Swing cutoff saws.** The requirements of this paragraph are also applicable to sliding cutoff saws mounted above the table.
- (1) Each swing cutoff saw shall be provided with a hood that will completely enclose the upper half of the saw, the arbor end, and the point of operation at all positions of the saw. The hood shall be constructed in such a manner and of such material that it will protect the operator from flying splinters and broken saw teeth. Its hood shall be so designed that it will automatically cover the lower portion of the blade, so that when the saw is returned to the back of the table the hood will rise on top of the fence, and when the saw is moved forward the hood will drop on top of and remain in contact with the table or material being cut.
  - (2) Each swing cutoff saw shall be provided with an effective device to return the saw automatically to the back of the table when released at any point of its travel. Such a device shall not depend

for its proper functioning upon any rope, cord, or spring. If there is a counterweight, the bolts supporting the bar and counterweight shall be provided with cotter pins; and the counterweight shall be prevented from dropping by either a bolt passing through both the bar and counterweight, or a bolt put through the extreme end of the bar, or, where the counterweight does not encircle the bar, a safety chain attached to it.

- (3) Limit chains or other equally effective devices shall be provided to prevent the saw from swinging beyond the front or back edges of the table, or beyond a forward position where the gullets of the lowest saw teeth will rise above the table top.
  - (4) Inverted swing cutoff saws shall be provided with a hood that will cover the part of the saw that protrudes above the top of the table or above the material being cut. It shall automatically adjust itself to the thickness of and remain in contact with the material being cut.
- (h) Radial saws.**
- (1) The upper hood shall completely enclose the upper portion of the blade down to a point that will include the end of the saw arbor. The upper hood shall be constructed in such a manner and of such material that it will protect the operator from flying splinters, broken saw teeth, etc., and will deflect sawdust away from the operator. The sides of the lower exposed portion of the blade shall be guarded to the full diameter of the blade by a device that will automatically adjust itself to the thickness of the stock and remain in contact with stock being cut to give maximum protection possible for the operation being performed.
  - (2) Each radial saw used for ripping shall be provided with nonkickback fingers or dogs located on both sides of the saw so as to oppose the thrust or tendency of the saw to pick up the material or to throw it back toward the operator. They shall be designed to provide adequate holding power for all the thicknesses of material being cut.
  - (3) An adjustable stop shall be provided to prevent the forward travel of the blade beyond the position necessary to complete the cut in repetitive operations.
  - (4) Installation shall be in such a manner that the front end of the unit will be slightly higher than the rear, so as to cause the cutting head to return gently to the starting position when released by the operator.
  - (5) Ripping and ploughing shall be against the direction in which the saw turns. The direction of the saw rotation shall be conspicuously marked on the hood. In addition, a permanent label not less than 1 1/2 inches by 3/4 inch shall be affixed to the rear of the guard at approximately the level of the arbor, reading as follows: "Danger: Do Not Rip or Plough From This End".
- (i) Bandsaws and band resaws.**
- (1) All portions of the saw blade shall be enclosed or guarded, except for the working portion of the blade between the bottom of the guide rolls and the table. Bandsaw wheels shall be fully encased. The outside periphery of the enclosure shall be solid. The front and back of the band wheels shall be either enclosed by solid material or by wire mesh or perforated metal. Such mesh or perforated metal shall be not less than 0.037 inch (U.S. Gage No. 20), and the openings shall be not greater than three-eighths inch. Solid material used for this purpose shall be of an equivalent strength and firmness. The guard for the portion of the blade between the sliding guide and the upper-saw-wheel guard shall protect the saw blade at the front and outer side. This portion of the guard shall be self-adjusting to raise and lower with the guide. The upper-wheel guard shall be made to conform to the travel of the saw on the wheel.
  - (2) Each bandsaw machine shall be provided with a tension control device to indicate a proper tension for the standard saws used on the machine, in order to assist in the elimination of saw breakage due to improper tension.
  - (3) Feed rolls of band resaws shall be protected with a suitable guard to prevent the hands of the operator from coming in contact with the in-running rolls at any point. The guard shall be constructed of heavy material, preferably metal, and the edge of the guard shall come to within three-eighths inch of the plane formed by the inside face of the feed roll in contact with the stock being cut.
- (j) Jointers.**
- (1) Each hand-fed planer and jointer with horizontal head shall be equipped with a cylindrical cutting head, the knife projection of which shall not exceed one-eighth inch beyond the cylindrical body of the head.

- (2) The opening in the table shall be kept as small as possible. The clearance between the edge of the rear table and the cutter head shall be not more than one-eighth inch. The table throat opening shall be not more than 2 1/2 inches when tables are set or aligned with each other for zero cut.
  - (3) Each hand-fed jointer with a horizontal cutting head shall have an automatic guard which will cover all the section of the head on the working side of the fence or gage. The guard shall effectively keep the operator's hand from coming in contact with the revolving knives. The guard shall automatically adjust itself to cover the unused portion of the head and shall remain in contact with the material at all times.
  - (4) Each hand-fed jointer with horizontal cutting head shall have a guard which will cover the section of the head back of the gage or fence.
  - (5) Each wood jointer with vertical head shall have either an exhaust hood or other guard so arranged as to enclose completely the revolving head, except for a slot of such width as may be necessary and convenient for the application of the material to be jointed.
- (k) Tenoning machines.**
- (1) Feed chains and sprockets of all double end tenoning machines shall be completely enclosed, except for that portion of chain used for conveying the stock.
  - (2) At the rear ends of frames over which feed conveyors run, sprockets and chains shall be guarded at the sides by plates projecting beyond the periphery of sprockets and the ends of lugs.
  - (3) Each tenoning machine shall have all cutting heads, and saws if used, covered by metal guards. These guards shall cover at least the unused part of the periphery of the cutting head. If such a guard is constructed of sheet metal, the material used shall be not less than one-sixteenth inch in thickness, and if cast iron is used, it shall be not less than three-sixteenths inch in thickness.
  - (4) Where an exhaust system is used, the guard shall form part or all of the exhaust hood and shall be constructed of metal of a thickness not less than that specified in subparagraph (3) of this paragraph.
- (l) Boring and mortising machines.**
- (1) Safety-bit chucks with no projecting set screws shall be used.
  - (2) Boring bits should be provided with a guard that will enclose all portions of the bit and chuck above the material being worked.
  - (3) The top of the cutting chain and driving mechanism shall be enclosed.
  - (4) If there is a counterweight, one of the following or equivalent means shall be used to prevent its dropping:
    - (i) It shall be bolted to the bar by means of a bolt passing through both bar and counterweight;
    - (ii) A bolt shall be put through the extreme end of the bar;
    - (iii) Where the counterweight does not encircle the bar, a safety chain shall be attached to it;
    - (iv) Other types of counterweights shall be suspended by chain or wire rope and shall travel in a pipe or other suitable enclosure wherever they might fall and cause injury.
  - (5) Universal joints on spindles of boring machines shall be completely enclosed in such a way as to prevent accidental contact by the operator.
  - (6) Each operating treadle shall be covered by an inverted U-shaped metal guard, fastened to the floor, and of adequate size to prevent accidental tripping.
- (m) Wood shapers and similar equipment.**
- (1) The cutting heads of each wood shaper, hand-fed panel raiser, or other similar machine not automatically fed, shall be enclosed with a cage or adjustable guard so designed as to keep the operator's hand away from the cutting edge. The diameter of circular shaper guards shall be not less than the greatest diameter of the cutter. In no case shall a warning device of leather or other material attached to the spindle be acceptable.
  - (2) [Reserved]
  - (3) All double-spindle shapers shall be provided with a spindle starting and stopping device for each spindle.
- (n) Planing, molding, sticking, and matching machines.**
- (1) Each planing, molding, sticking, and matching machine shall have all cutting heads, and saws if used, covered by a metal guard. If such guard is constructed of sheet metal, the material used

shall be not less than 1/16 inch in thickness, and if cast iron is used, it shall be not less than three-sixteenths inch in thickness.

- (2) Where an exhaust system is used, the guards shall form part or all of the exhaust hood and shall be constructed of metal of a thickness not less than that specified in paragraph (h)(1) of this section.
  - (3) Feed rolls shall be guarded by a hood or suitable guard to prevent the hands of the operator from coming in contact with the in-running rolls at any point. The guard shall be fastened to the frame carrying the rolls so as to remain in adjustment for any thickness of stock.
  - (4) Surfacers or planers used in thickening multiple pieces of material simultaneously shall be provided with sectional infeed rolls having sufficient yield in the construction of the sections to provide feeding contact pressure on the stock, over the permissible range of variation in stock thickness specified or for which the machine is designed. In lieu of such yielding sectional rolls, suitable section kickback finger devices shall be provided at the infeed end.
- (o) Profile and swing-head lathes and wood heel turning machine.**
- (1) Each profile and swing-head lathe shall have all cutting heads covered by a metal guard. If such a guard is constructed of sheet metal, the material used shall be not less than one-sixteenth inch in thickness; and if cast iron is used, it shall not be less than three-sixteenths inch in thickness.
  - (2) Cutting heads on wood-turning lathes, whether rotating or not, shall be covered as completely as possible by hoods or shields.
  - (3) Shoe last and spoke lathes, doweling machines, wood heel turning machines, and other automatic wood-turning lathes of the rotating knife type shall be equipped with hoods enclosing the cutter blades completely except at the contact points while the stock is being cut.
  - (4) Lathes used for turning long pieces of wood stock held only between the two centers shall be equipped with long curved guards extending over the tops of the lathes in order to prevent the work pieces from being thrown out of the machines if they should become loose.
  - (5) Where an exhaust system is used, the guard shall form part or all of the exhaust hood and shall be constructed of metal of a thickness not less than that specified in subparagraph (1) of this paragraph.
- (p) Sanding machines.**
- (1) Feed rolls of self-feed sanding machines shall be protected with a semicylindrical guard to prevent the hands of the operator from coming in contact with the in-running rolls at any point. The guard shall be constructed of heavy material, preferably metal, and firmly secured to the frame carrying the rolls so as to remain in adjustment for any thickness of stock. The bottom of the guard should come down to within three-eighths inch of a plane formed by the bottom or contact face of the feed roll where it touches the stock.
  - (2) Each drum sanding machine shall have an exhaust hood, or other guard if no exhaust system is required, so arranged as to enclose the revolving drum, except for that portion of the drum above the table, if a table is used, which may be necessary and convenient for the application of the material to be finished.
  - (3) Each disk sanding machine shall have the exhaust hood, or other guard if no exhaust system is required, so arranged as to enclose the revolving disk, except for that portion of the disk above the table, if a table is used, which may be necessary for the application of the material to be finished.
  - (4) Belt sanding machines shall be provided with guards at each nip point where the sanding belt runs on to a pulley. These guards shall effectively prevent the hands or fingers of the operator from coming in contact with the nip points. The unused run of the sanding belt shall be guarded against accidental contact.
- (q) Veneer cutters and wringers.**
- (1) Veneer slicer knives shall be guarded to prevent accidental contact with knife edge, at both front and rear.
  - (2) Veneer clippers shall have automatic feed or shall be provided with a guard which will make it impossible to place a finger or fingers under the knife while feeding or removing the stock.
  - (3) Sprockets on chain or slat-belt conveyors shall be enclosed.
  - (4) Where practicable, hand and footpower guillotine veneer cutters shall be provided with rods or plates or other satisfactory means, so arranged on the feeding side that the hands cannot reach the cutting edge of the knife while feeding or holding the stock in place.

- (5) Power-driven guillotine veneer cutters, except continuous feed trimmers, shall be equipped with:
    - (i) Starting devices which require the simultaneous action of both hands to start the cutting motion and of at least one hand on a control during the complete stroke of the knife; or
    - (ii) An automatic guard which will remove the hands of the operator from the danger zone at every descent of the blade, used in conjunction with one-hand starting devices which require two distinct movements of the device to start the cutting motion, and so designed as to return positively to the nonstarting position after each complete cycle of the knife.
  - (6) Where two or more workers are employed at the same time on the same power-driven guillotine veneer cutter equipped with two-hand control, the device shall be so arranged that each worker shall be required to use both hands simultaneously on the controls to start the cutting motion, and at least one hand on a control to complete the cut.
  - (7) Power-driven guillotine veneer cutters, other than continuous trimmers, shall be provided, in addition to the brake or other stopping mechanism, with an emergency device which will prevent the machine from operating in the event of failure of the brake when the starting mechanism is in the nonstarting position.
- (r) Miscellaneous woodworking machines.**
- (1) The feed rolls of roll type glue spreaders shall be guarded by a semicylindrical guard. The bottom of the guard shall come to within three-eighths inch of a plane formed by bottom or contact face of the feed roll where it touches the stock.
  - (2) Drag saws shall be so located as to give at least a 4-foot clearance for passage when the saw is at the extreme end of the stroke; or if such clearance is not obtainable, the saw and its driving mechanism shall be provided with a standard enclosure.
  - (3) For combination or universal woodworking machines each point of operation of any tool shall be guarded as required for such a tool in a separate machine.
  - (4) The mention of specific machines in paragraphs (a) thru (q) and this paragraph (r) of this section, inclusive, is not intended to exclude other woodworking machines from the requirement that suitable guards and exhaust hoods be provided to reduce to a minimum the hazard due to the point of operation of such machines.
- (s) Inspection and maintenance of woodworking machinery.**
- (1) Dull, badly set, improperly filed, or improperly tensioned saws shall be immediately removed from service, before they begin to cause the material to stick, jam, or kick back when it is fed to the saw at normal speed. Saws to which gum has adhered on the sides shall be immediately cleaned.
  - (2) All knives and cutting heads of woodworking machines shall be kept sharp, properly adjusted, and firmly secured. Where two or more knives are used in one head, they shall be properly balanced.
  - (3) Bearings shall be kept free from lost motion and shall be well lubricated.
  - (4) Arbors of all circular saws shall be free from play.
  - (5) Sharpening or tensioning of saw blades or cutters shall be done only by persons of demonstrated skill in this kind of work.
  - (6) Emphasis is placed upon the importance of maintaining cleanliness around woodworking machinery, particularly as regards the effective functioning of guards and the prevention of fire hazards in switch enclosures, bearings, and motors.
  - (7) All cracked saws shall be removed from service.
  - (8) The practice of inserting wedges between the saw disk and the collar to form what is commonly known as a "wobble saw" shall not be permitted.
  - (9) Push sticks or push blocks shall be provided at the work place in the several sizes and types suitable for the work to be done.
  - (10)-(11) [Reserved]
  - (12) The knife blade of jointers shall be so installed and adjusted that it does not protrude more than one-eighth inch beyond the cylindrical body of the head. Push sticks or push blocks shall be provided at the work place in the several sizes and types suitable for the work to be done.
  - (13) Whenever veneer slicers or rotary veneer-cutting machines have been shutdown for the purpose of inserting logs or to make adjustments, operators shall make sure that machine is clear and other workmen are not in a hazardous position before starting the machine.
  - (14) Operators shall not ride the carriage of a veneer slicer.

**§1910.214 Cooperage machinery. [Reserved]**

**§1910.215 Abrasive wheel machinery.**

**(a) General requirements.**

- (1) Machine guarding. Abrasive wheels shall be used only on machines provided with safety guards as defined in the following paragraphs of this section, except:
  - (i) Wheels used for internal work while within the work being ground;
  - (ii) Mounted wheels, used in portable operations, 2 inches and smaller in diameter; and
  - (iii) Types 16, 17, 18, 18R, and 19 cones, plugs, and threaded hole pot balls where the work offers protection.
- (2) Guard design. The safety guard shall cover the spindle end, nut, and flange projections. The safety guard shall be mounted so as to maintain proper alignment with the wheel, and the strength of the fastenings shall exceed the strength of the guard, except:
  - (i) Safety guards on all operations where the work provides a suitable measure of protection to the operator, may be so constructed that the spindle end, nut, and outer flange are exposed; and where the nature of the work is such as to entirely cover the side of the wheel, the side covers of the guard may be omitted; and
  - (ii) The spindle end, nut, and outer flange may be exposed on machines designed as portable saws.
- (3) Flanges. Grinding machines shall be equipped with flanges in accordance with paragraph (c) of this section.
- (4) Work rests. On offhand grinding machines, work rests shall be used to support the work. They shall be of rigid construction and designed to be adjustable to compensate for wheel wear. Work rests shall be kept adjusted closely to the wheel with a maximum opening of one-eighth inch to prevent the work from being jammed between the wheel and the rest, which may cause wheel breakage. The work rest shall be securely clamped after each adjustment. The adjustment shall not be made with the wheel in motion.
- (5) Excluded machinery. Natural sandstone wheels and metal, wooden, cloth, or paper discs, having a layer of abrasive on the surface are not covered by this section.

**(b) Guarding of abrasive wheel machinery.**

- (1) Cup wheels. Cup wheels (Types 6 and 11) shall be protected by:
  - (i) Safety guards as specified in paragraphs (b) (1) through (10) of this section;
  - (ii) Band type guards as specified in paragraph (b) (11) of this section; and
  - (iii) Special "Revolving Cup Guards" which mount behind the wheel and turn with it. They shall be made of steel or other material with adequate strength and shall enclose the wheel sides upward from the back for one-third of the wheel thickness. The mounting features shall conform with all requirements of this section. It is necessary to maintain clearance between the wheel side and the guard. This clearance shall not exceed one-sixteenth inch.
- (2) Guard exposure angles. The maximum exposure angles specified in paragraphs (b)(3) through (8) of this section shall not be exceeded. Visors or other accessory equipment shall not be included as a part of the guard when measuring the guard opening, unless such equipment has strength equal to that of the guard.
- (3) Bench and floor stands. The angular exposure of the grinding wheel periphery and sides for safety guards used on machines known as bench and floor stands should not exceed 90° or one-fourth of the periphery. This exposure shall begin at a point not more than 65° above the horizontal plane of the wheel spindle. (See Figures O-6 and O-7 and paragraph (b)(9) of this section.)

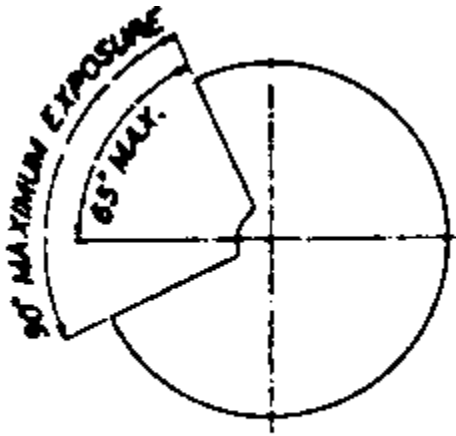

FIGURE NO. O-6

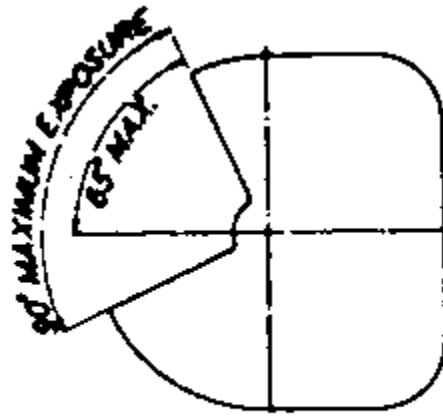

FIGURE NO. O-7

Wherever the nature of the work requires contact with the wheel below the horizontal plane of the spindle, the exposure shall not exceed 125°. (See Figures O-8 and O-9.)

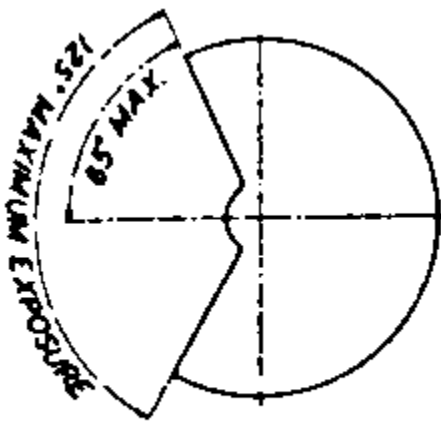

FIGURE NO. O-8

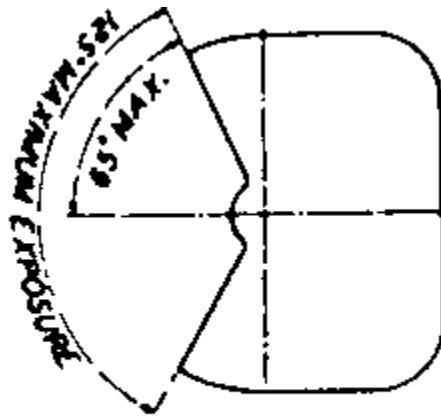

FIGURE NO. O-9

- (4) Cylindrical grinders. The maximum angular exposure of the grinding wheel periphery and sides for safety guards used on cylindrical grinding machines shall not exceed  $180^\circ$ . This exposure shall begin at a point not more than  $65^\circ$  above the horizontal plane of the wheel spindle. (See Figures O-10 and O-11 and subparagraph (9) of this paragraph.)

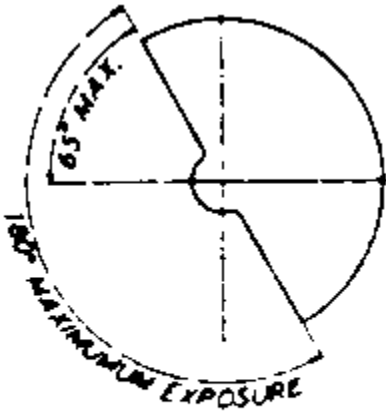

FIGURE NO. O-10

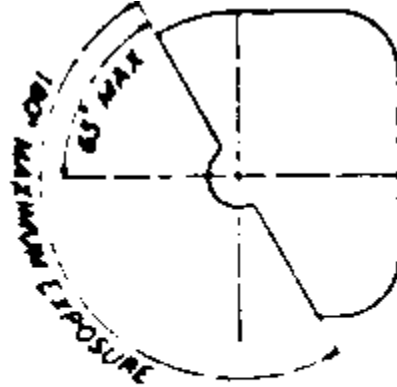

FIGURE NO. O-11

- (5) Surface grinders and cutting-off machines. The maximum angular exposure of the grinding wheel periphery and sides for safety guards used on cutting-off machines and on surface grinding machines which employ the wheel periphery shall not exceed  $150^\circ$ . This exposure shall begin at a point not less than  $15^\circ$  below the horizontal plane of the wheel spindle. (See Figures O-12 and O-13)

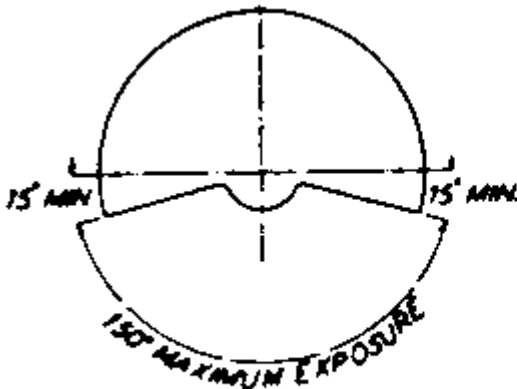

FIGURE NO. O-12

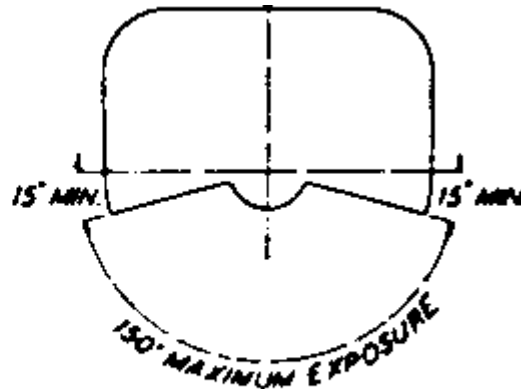

FIGURE NO. O-13

- (6) Swing frame grinders. The maximum angular exposure of the grinding wheel periphery and sides for safety guards used on machines known as swing frame grinding machines shall not exceed 180°, and the top half of the wheel shall be enclosed at all times. (See Figures O-14 and O-15.)

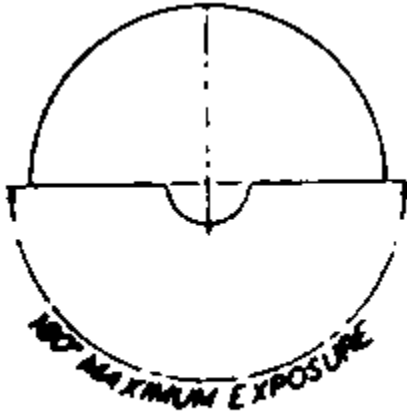

FIGURE NO. O-14

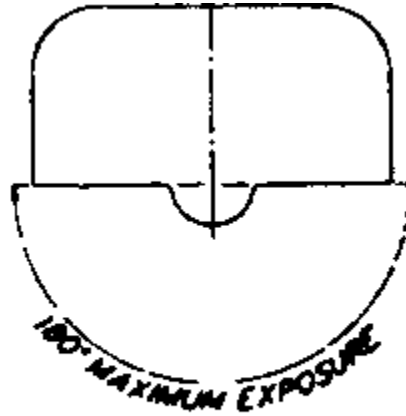

FIGURE NO. O-15

- (7) Automatic snagging machines. The maximum angular exposure of the grinding wheel periphery and sides for safety guards used on grinders known as automatic snagging machines shall not exceed 180° and the top half of the wheel shall be enclosed at all times. (See Figures O-14 and O-15.)
- (8) Top grinding. Where the work is applied to the wheel above the horizontal centerline, the exposure of the grinding wheel periphery shall be as small as possible and shall not exceed 60°. (See Figures O-16 and O-17.)

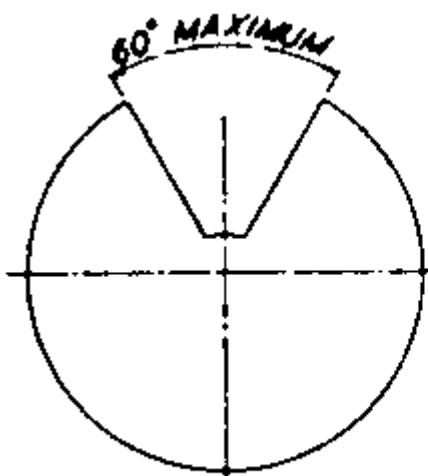

FIGURE NO. O-16

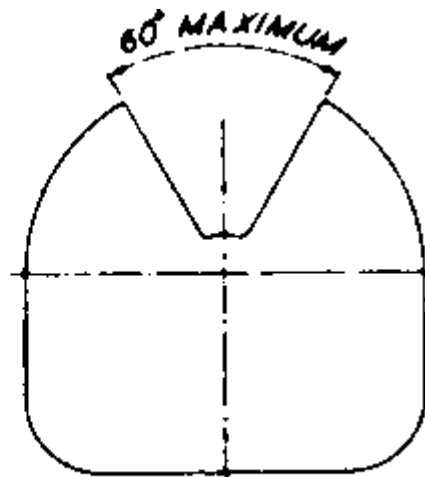

FIGURE NO. O-17

- (9) Exposure adjustment. Safety guards of the types described in Subparagraphs (3) and (4) of this paragraph, where the operator stands in front of the opening, shall be constructed so that the peripheral protecting member can be adjusted to the constantly decreasing diameter of the wheel. The maximum angular exposure above the horizontal plane of the wheel spindle as specified in paragraphs (b)(3) and (4) of this section shall never be exceeded, and the distance between the wheel periphery and the adjustable tongue or the end of the peripheral member at the top shall never exceed one-fourth inch. (See Figures O-18, O-19, O-20, O-21, O-22, and O-23.)
- (10) Material requirements and minimum dimensions.
- (i) See Figures O-36 and O-37 and Table O-9 for minimum basic thickness of peripheral and side members for various types of safety guards and classes of service.
  - (ii) If operating speed does not exceed 8,000 surface feet per minute cast iron safety guards, malleable iron guards or other guards as described in paragraph (b)(10)(iii) of this section shall be used.
  - (iii) Cast steel, or structural steel, safety guards as specified in Figures O-36 and O-37 and Table O-9 shall be used where operating speeds of wheels are faster than 8,000 surface feet per minute up to a maximum of 16,000 surface feet per minute.
  - (iv) For cutting-off wheels 16 inches diameter and smaller and where speed does not exceed 16,000 surface feet per minute, cast iron or malleable iron safety guards as specified in Figures O-36 and O-37, and in Table O-9 shall be used.

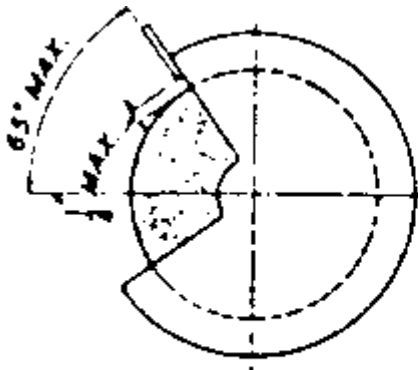

FIGURE NO. O-18

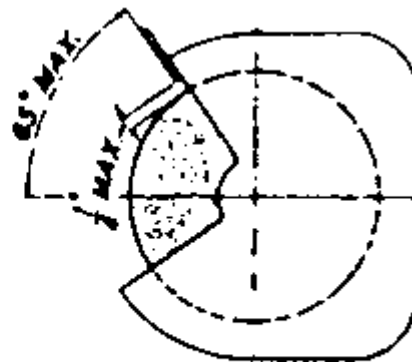

FIGURE NO. O-19

Showing adjustable tongue giving required angular protection for all sizes of wheel used.

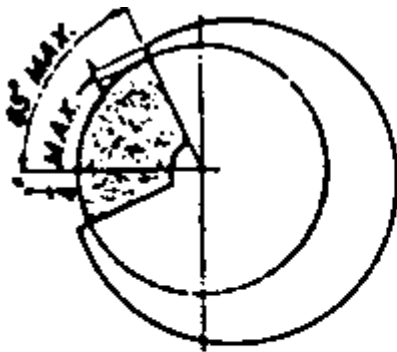

FIGURE NO. O-20

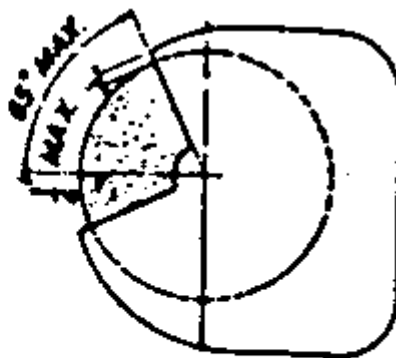

FIGURE NO. O-21

**CORRECT**

Showing movable guard with opening small enough to give required protection for smallest size wheel used.

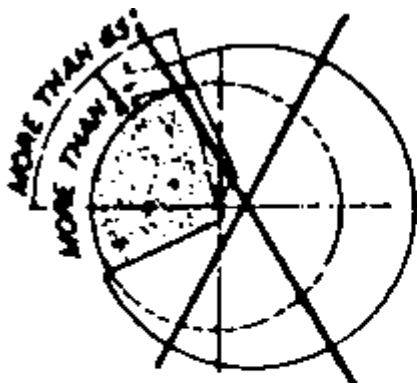

FIGURE NO. O-22

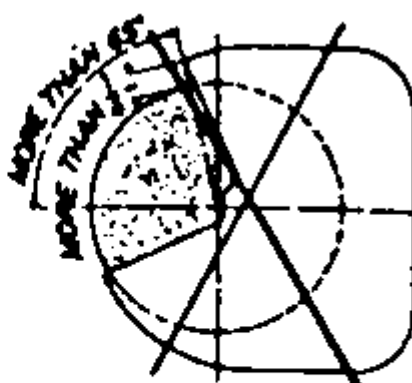

FIGURE NO. O-23

**INCORRECT**

Showing movable guard with size of opening correct for full size wheel but too large for smaller wheels.

- (v) For cutting-off wheels larger than 16 inches diameter and where speed does not exceed 14,200 surface feet per minute, safety guards as specified in Figures O-27 and O-28, and in Table O-1 shall be used.
- (vi) For thread grinding wheels not exceeding 1 inch in thickness cast iron or malleable iron safety guards as specified in Figures O-36 and O-37, and in Table O-9 shall be used.
- (11) Band type guards-general specifications. Band type guards shall conform to the following general specifications:

- (i) The bands shall be of steel plate or other material of equal or greater strength. They shall be continuous, the ends being either riveted, bolted, or welded together in such a manner as to leave the inside free from projections.
  - (ii) The inside diameter of the band shall not be more than 1 inch larger than the outside diameter of the wheel, and shall be mounted as nearly concentric with the wheel as practicable.
  - (iii) The band shall be of sufficient width and its position kept so adjusted that at no time will the wheel protrude beyond the edge of the band a distance greater than that indicated in Figure O-29 and in Table O-2 or the wall thickness (W), whichever is smaller.
- (12) Guard design specifications. Abrasive wheel machinery guards shall meet the design specifications of the American National Standard Safety Code for the Use, Care, and Protection of Abrasive Wheels, ANSI B7.1-1970, which is incorporated by reference as specified in §1910.6. This requirement shall not apply to natural sandstone wheels or metal, wooden, cloth, or paper discs, having a layer of abrasive on the surface.
- (c) Flanges.**
- (1) General requirements. All abrasive wheels shall be mounted between flanges which shall not be less than one-third the diameter of the wheel.
    - (i) Exceptions:
      - (a) Mounted wheels.
      - (b) Portable wheels with threaded inserts or projecting studs.
      - (c) Abrasive discs (inserted nut, inserted washer and projecting stud type).
      - (d) Plate mounted wheels.
      - (e) Cylinders, cup, or segmental wheels that are mounted in chucks.
      - (f) Types 27 and 28 wheels.
      - (g) Certain internal wheels.
      - (h) Modified types 6 and 11 wheels (terrazzo).
      - (i) Cutting-off wheels, Types 1 and 27A (see paragraphs (c)(1) (ii) and (iii) of this section).
    - (ii) Type 1 cutting-off wheels are to be mounted between properly relieved flanges which have matching bearing surfaces. Such flanges shall be at least one-fourth the wheel diameter.
    - (iii) Type 27A cutting-off wheels are designed to be mounted by means of flat, not relieved, flanges having matching bearing surfaces and which may be less than one-third but shall not be less than one-fourth the wheel diameter. (See Figure O-24 for one such type of mounting.)
    - (iv) There are three general types of flanges:
      - (a) Straight relieved flanges (see Figure O-32);
      - (b) Straight unrelieved flanges (see Figure O-30);
      - (c) Adaptor flanges (see Figures O-33 and O-34);
    - (v) Regardless of flange type used, the wheel shall always be guarded. Blotters shall be used in accordance with paragraph (c)(6) of this section.

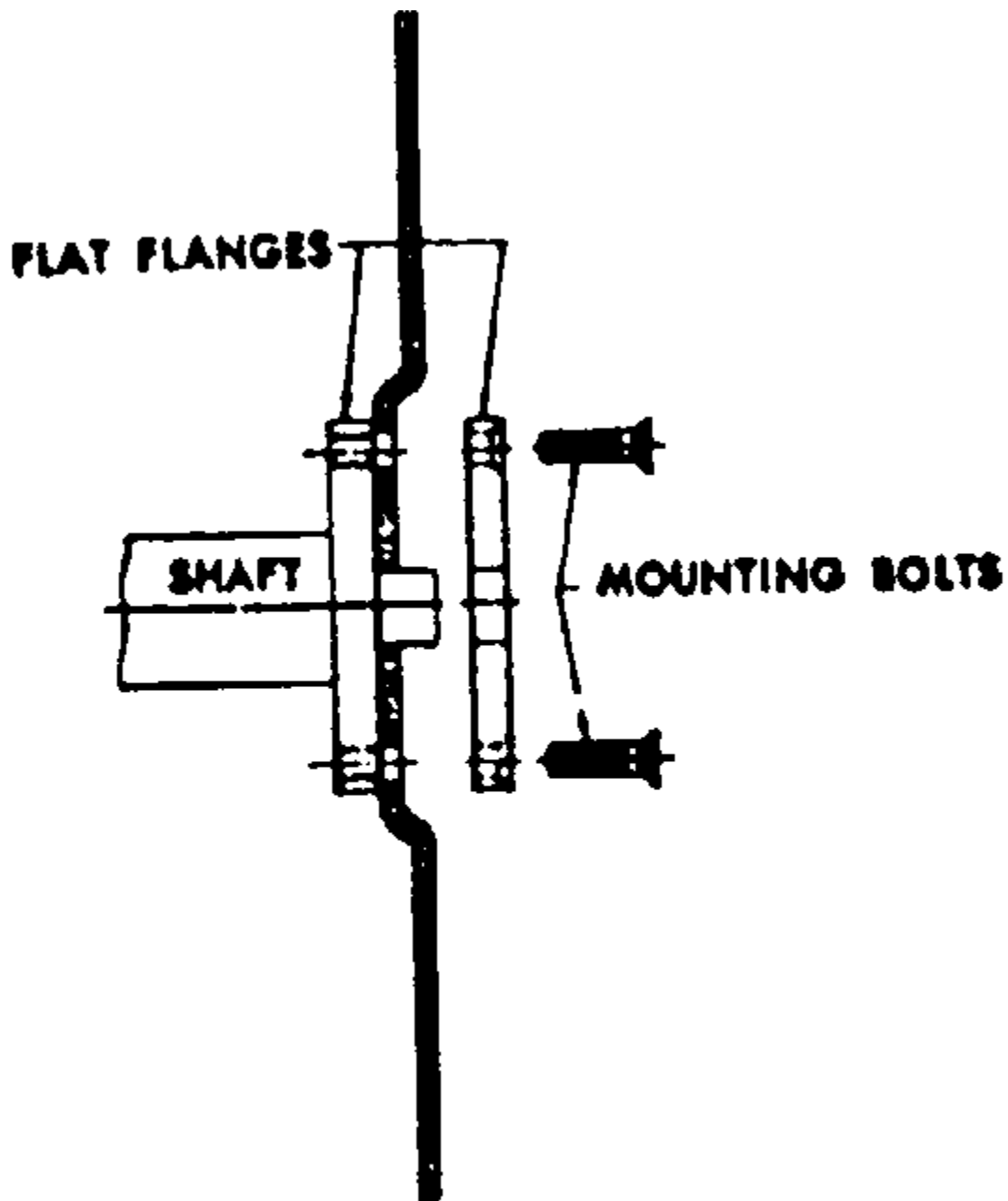
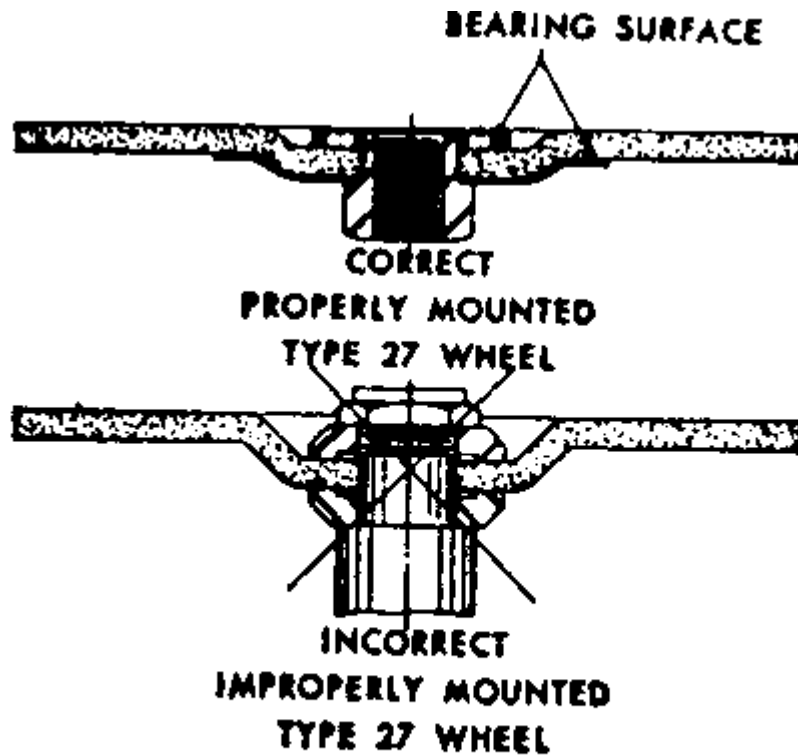

**FIGURE NO. O-24**

The Type 27 A Wheel is mounted between flat non-relieved flanges of equal bearing surfaces.

- (2) [Reserved]
- (3) Finish and balance. Flanges shall be dimensionally accurate and in good balance. There shall be no rough surfaces or sharp edges.

- (4) Uniformity of diameter.
- (i) Both flanges, of any type, between which a wheel is mounted, shall be of the same diameter and have equal bearing surface. Exceptions are set forth in the remaining subdivisions of this subparagraph.
  - (ii) Type 27 and Type 28 wheels, because of their shape and usage, require specially designed adaptors. The back flange shall extend beyond the central hub or raised portion and contact the wheel to counteract the side pressure on the wheel in use. The adaptor nut which is less than the minimum one-third diameter of wheel fits in the depressed side of wheel to prevent interference in side grinding and serves to drive the wheel by its clamping force against the depressed portion of the back flange. The variance in flange diameters, the adaptor nut being less than one-third wheel diameter, and the use of side pressure in wheel operation limits the use to reinforced organic bonded wheels. Mounts which are affixed to the wheel by the manufacturer shall not be reused. Type 27 and Type 28 wheels shall be used only with a safety guard located between wheel and operator during use. (See Figure O-24-A.)



**FIGURE NO. O-24-A**

Types 27 and 28 wheels, because of their shape, require specially designed adaptors.

- (iii) Modified Types 6 and 11 wheels (terrazzo) with tapered K dimension.
- (5) Recess and undercut.

- (i) Straight relieved flanges made according to Table O-6 and Figure O-32 shall be recessed at least one-sixteenth inch on the side next to the wheel for a distance as specified in Table O-6.
  - (ii) Straight flanges of the adaptor or sleeve type (Table O-7 and Figures O-33 and O-34) shall be undercut so that there will be no bearing on the sides of the wheel within one-eighth inch of the arbor hole.
- (6) Blotters.
- (i) Blotters (compressible washers) shall always be used between flanges and abrasive wheel surfaces to insure uniform distribution of flange pressure. (See paragraph (d)(5) of this section.)
  - (ii) Exception:
    - (a) Mounted wheels.
    - (b) Abrasive discs (inserted nut, inserted washer, and projecting stud type).
    - (c) Plate mounted wheels.
    - (d) Cylinders, cups, or segmental wheels that are mounted in chucks.
    - (e) Types 27 and 28 wheels.
    - (f) Certain Type 1 and Type 27A cutting-off wheels.
    - (g) Certain internal wheels.
    - (h) Type 4 tapered wheels.
    - (i) Diamond wheels, except certain vitrified diamond wheels.
    - (j) Modified Types 6 and 11 wheel (terrazzo)-blotters applied flat side of wheel only.
- (7) Driving flange. The driving flange shall be securely fastened to the spindle and the bearing surface shall run true. When more than one wheel is mounted between a single set of flanges, wheels may be cemented together or separated by specially designed spacers. Spacers shall be equal in diameter to the mounting flanges and have equal bearing surfaces. (See paragraph (d)(6) of this section.)
- (8) Dimensions.
- (i) Tables O-4 and O-6 and Figures O-30 and O-32 show minimum dimensions for straight relieved and unrelieved flanges for use with wheels with small holes that fit directly on the machine spindle. Dimensions of such flanges shall never be less than indicated.
  - (ii) Table O-5, and Table O-7 and Figures O-31, O-33, O-34 show minimum dimensions for straight adaptor flanges for use with wheels having holes larger than the spindle. Dimensions of such adaptor flanges shall never be less than indicated.
  - (iii) Table O-8 and Figure O-35 show minimum dimensions for straight flanges that are an integral part of wheel sleeves which are frequently used on precision grinding machines. Dimensions of such flanges shall never be less than indicated.
- (9) Repairs and maintenance. All flanges shall be maintained in good condition. When the bearing surfaces become worn, warped, sprung, or damaged they should be trued or refaced. When refacing or truing, care shall be exercised to make sure that proper relief and rigidity is maintained as specified in paragraphs (c) (2) and (5) of this section and they shall be replaced when they do not conform to these subparagraphs and Table O-4, Figure O-30, Table O-5, Figure O-31, Table O-6, Figure O-32, and Table O-8, Figure O-35. Failure to observe these rules might cause excessive flange pressure around the hole of the wheel. This is especially true of wheel-sleeve or adaptor flanges.
- (d) Mounting.**
- (1) Inspection. Immediately before mounting, all wheels shall be closely inspected and sounded by the user (ring test) to make sure they have not been damaged in transit, storage, or otherwise. The spindle speed of the machine shall be checked before mounting of the wheel to be certain that it does not exceed the maximum operating speed marked on the wheel. Wheels should be tapped gently with a light nonmetallic implement, such as the handle of a screwdriver for light wheels, or a wooden mallet for heavier wheels. If they sound cracked (dead), they shall not be used. This is known as the "Ring Test".
    - (i) Wheels must be dry and free from sawdust when applying the ring test, otherwise the sound will be deadened. It should also be noted that organic bonded wheels do not emit the same clear metallic ring as do vitrified and silicate wheels.

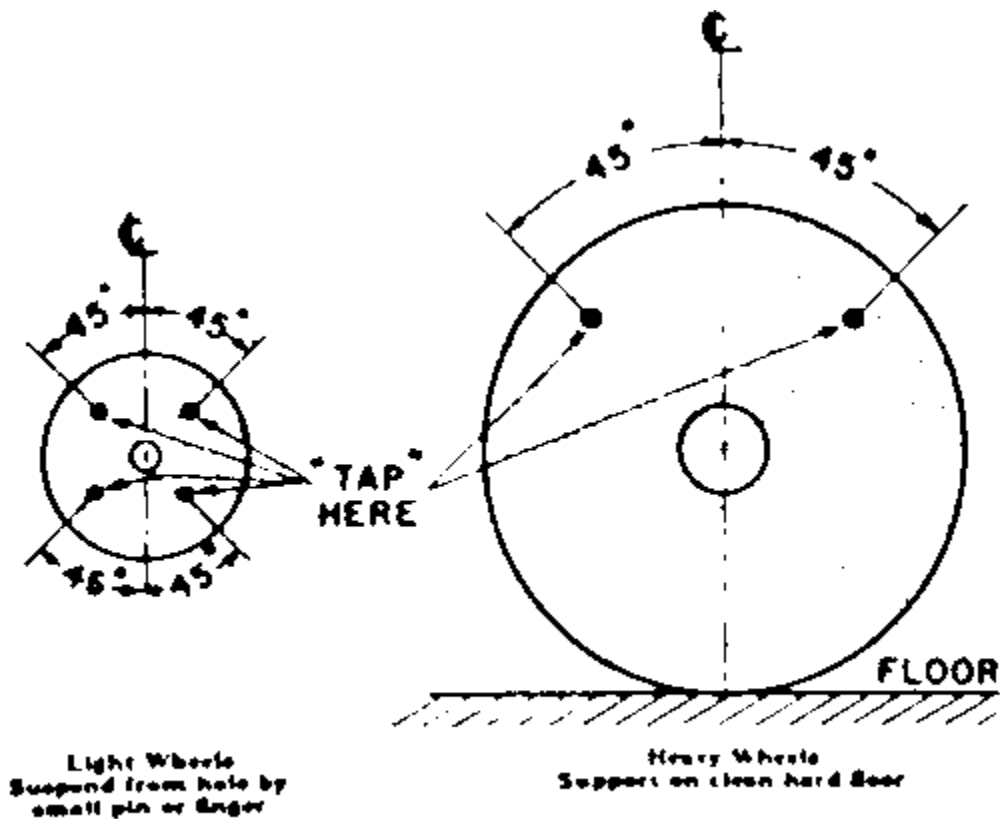
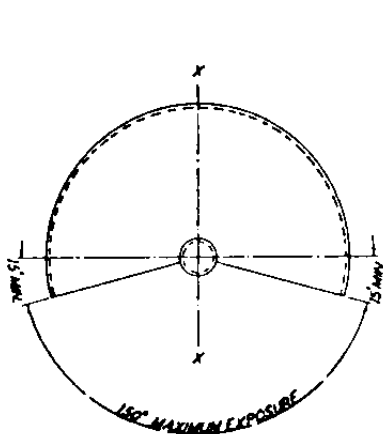

FIGURE NO. O-25

FIGURE NO. O-26

- (ii) "Tap" wheels about 45° each side of the vertical centerline and about 1 or 2 inches from the periphery as indicated by the spots in Figure O-25 and Figure O-26. Then rotate the wheel 45° and repeat the test. A sound and undamaged wheel will give a clear metallic tone. If cracked, there will be a dead sound and not a clear "ring."
- (2) Arbor size. Grinding wheels shall fit freely on the spindle and remain free under all grinding conditions. A controlled clearance between the wheel hole and the machine spindle (or wheel sleeves or adaptors) is essential to avoid excessive pressure from mounting and spindle expansion. To accomplish this, the machine spindle shall be made to nominal (standard) size plus zero minus 0.002 inch, and the wheel hole shall be made suitably oversize to assure safety clearance under the conditions of operating heat and pressure.
- (3) Surface condition. All contact surfaces of wheels, blotters and flanges shall be flat and free of foreign matter.
- (4) Bushing. When a bushing is used in the wheel hole it shall not exceed the width of the wheel and shall not contact the flanges.
- (5) Blotters. When blotters or flange facings of compressible material are required, they shall cover entire contact area of wheel flanges. Blotters need not be used with the following types of wheels:
  - (i) Mounted wheels.
  - (ii) Abrasive discs (inserted nut, inserted washer, and projecting-stud type).

- (iii) Plate mounted wheels.
  - (iv) Cylinders, cups, or segmental wheels that are mounted in chucks.
  - (v) Types 27 and 28 wheels.
  - (vi) Certain Type 1 and Type 27A cutting-off wheels.
  - (vii) Certain internal wheels.
  - (viii) Type 4 tapered wheels.
  - (ix) Diamond wheels, except certain vitrified diamond wheels.
- (6) Multiple wheel mounting. When more than one wheel is mounted between a single set of flanges, wheels may be cemented together or separated by specially designed spacers. Spacers shall be equal in diameter to the mounting flanges and have equal bearing surfaces. When mounting wheels which have not been cemented together, or ones which do not utilize separating spacers, care must be exercised to use wheels specially manufactured for that purpose.



**FIGURE NO. 0-27**

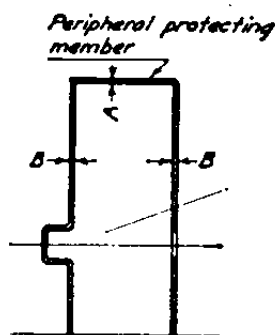

*Section X-X*

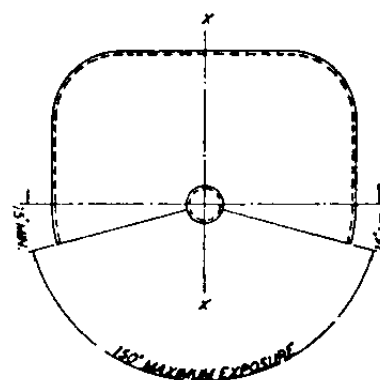

**FIGURE NO. 0-28**

**TABLE O-1--MINIMUM BASIC THICKNESS FOR PERIPHERAL AND SIDE MEMBERS FOR SAFETY GUARDS USED WITH CUTTING-OFF WHEELS**

| Material used in construction of guard                  | Maximum thickness of cutting off wheel | Speed not to exceed | Cutting off wheel diameters |      |                      |      |                      |     |                      |      |                      |     |
|---------------------------------------------------------|----------------------------------------|---------------------|-----------------------------|------|----------------------|------|----------------------|-----|----------------------|------|----------------------|-----|
|                                                         |                                        |                     | 6 to 11 inches              |      | Over 11 to 20 inches |      | Over 20 to 30 inches |     | Over 30 to 48 inches |      | Over 48 to 72 inches |     |
|                                                         |                                        |                     | A                           | B    | A                    | B    | A                    | B   | A                    | B    | A                    | B   |
| Structural steel (min. tensile strength 60,000 p.s.i.). | 1/2 inch or less                       | 14,200 SFPM.        | 1/16                        | 1/16 | 3/32                 | 3/32 | 1/8                  | 1/8 | 3/16                 | 3/16 | 1/4                  | 1/4 |
|                                                         | 1/2 inch or less                       | 16,000 SFPM.        | 3/32                        | 1/8  | 1/8                  | 1/8  | 3/16                 | 1/8 | 1/4                  | 3/16 | 5/16                 | 1/4 |

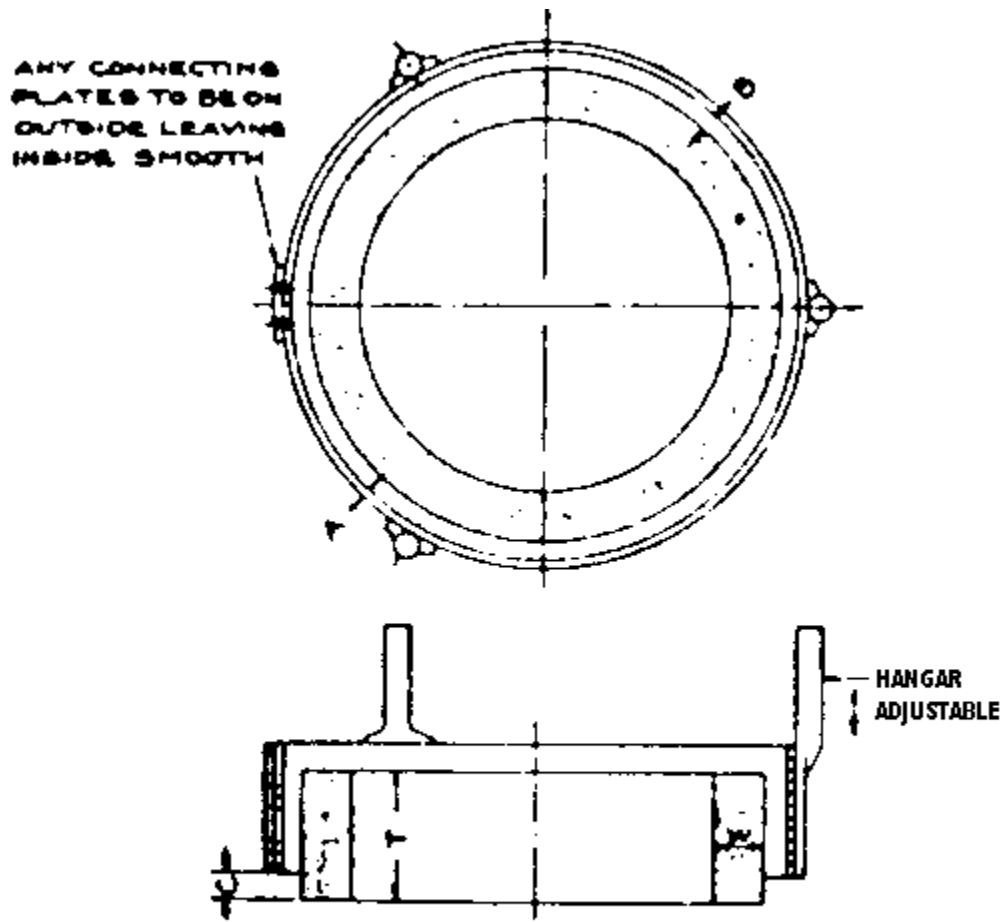

DIMENSION B NOT TO EXCEED 1/4 " (QUARTER OF AN INCH)

**FIGURE NO. 0-29**

TABLE O-3--GUIDE FOR CONSTRUCTION OF BAND TYPE GUARDS  
 [Maximum Wheel Speed 7,000 SFPM]

| Minimum material specifications | Diameter of wheel   | Minimum thickness of band A | Minimum diameter of rivets | Maximum distance between centers of rivets |
|---------------------------------|---------------------|-----------------------------|----------------------------|--------------------------------------------|
|                                 | Inches              |                             |                            |                                            |
| Hot rolled steel SAE 1008 ..... | Under 8 .....       | 1/16                        | 3/16                       | 3/4                                        |
|                                 | 8 to 24 .....       | 1/8                         | 1/4                        | 1                                          |
|                                 | Over 24 to 30 ..... | 1/4                         | 3/8                        | 1 1/4                                      |

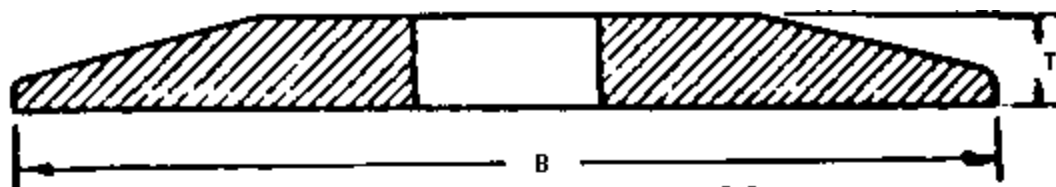

**FIGURE NO. 0-30**

*Driving flange secured to spindle for use only on portable wheels with threaded inserts or projecting studs.*

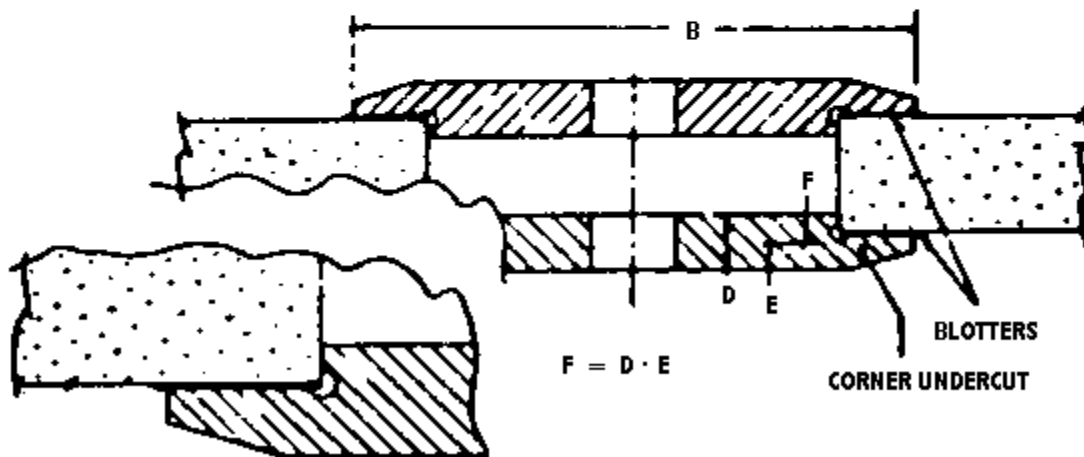

**FIGURE NO. 0-31**

Driving flange secured to spindle for use only on portable wheels with threaded inserts or projecting studs.

TABLE O-5--MINIMUM DIMENSIONS FOR STRAIGHT ADAPTOR FLANGE--

FOR ORGANIC BONDED WHEELS OVER 1 1/4 INCHES THICK<sup>1</sup>  
[In inches]

| Wheel diameter            | Wheel hole diameter | B-Minimum flange diameter | D-Minimum thickness of flange at bore | E-Minimum thickness of flange at edge of undercut | F <sup>1</sup> -(D-E) Minimum thickness |
|---------------------------|---------------------|---------------------------|---------------------------------------|---------------------------------------------------|-----------------------------------------|
| 12 to 14 .....            | 4                   | 6                         | 7/8                                   | 3/8                                               | 1/2                                     |
|                           | 5                   | 7                         | 7/8                                   | 3/8                                               | 1/2                                     |
|                           | 6                   | 8                         | 7/8                                   | 3/8                                               | 1/2                                     |
| Larger than 14 to 18..... | 4                   | 6                         | 7/8                                   | 3/8                                               | 1/2                                     |
|                           | 5                   | 7                         | 7/8                                   | 3/8                                               | 1/2                                     |
|                           | 6                   | 8                         | 7/8                                   | 3/8                                               | 1/2                                     |
|                           | 7                   | 9                         | 7/8                                   | 3/8                                               | 1/2                                     |
|                           | 8                   | 10                        | 7/8                                   | 3/8                                               | 1/2                                     |
| Larger than 18 to 24..... | 6                   | 8                         | 1                                     | 1/2                                               | 1/2                                     |
|                           | 7                   | 9                         | 1                                     | 1/2                                               | 1/2                                     |
|                           | 8                   | 10                        | 1                                     | 1/2                                               | 1/2                                     |
|                           | 10                  | 12                        | 1                                     | 1/2                                               | 1/2                                     |
|                           | 12                  | 14                        | 1                                     | 1/2                                               | 1/2                                     |
| Larger than 24 to 30..... | 12                  | 15                        | 1                                     | 1/2                                               | 1/2                                     |
| Larger than 30 to 36..... | 12                  | 15                        | 1 3/8                                 | 7/8                                               | 1/2                                     |

<sup>1</sup>For wheels under 1 1/4 inches thick F dimension shall not exceed 40 percent of wheel thickness.

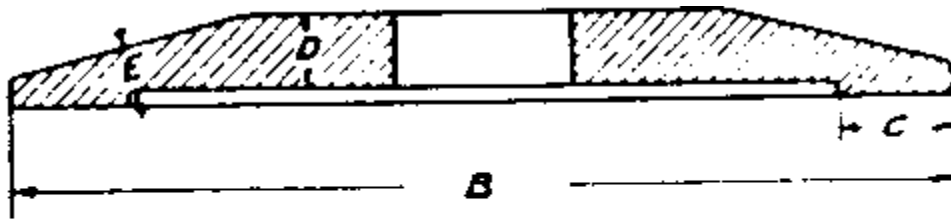

**FIGURE NO . 0-32**

*Driving flange secured to spindle.*

TABLE O-6--MINIMUM DIMENSIONS FOR STRAIGHT RELIEVED FLANGES<sup>1</sup>

[In inches]

| A-Diameter of wheel | B-Minimum outside diameter of flanges | C-Radial width of bearing surface |         | D-Minimum thickness of flange at bore | E-Minimum thickness of flange at edge of recess |
|---------------------|---------------------------------------|-----------------------------------|---------|---------------------------------------|-------------------------------------------------|
|                     |                                       | Minimum                           | Maximum |                                       |                                                 |
| 1 .....             | 3/8                                   | 1/16                              | 1/8     | 1/16                                  | 1/16                                            |
| 2 .....             | 3/4                                   | 1/8                               | 3/16    | 1/8                                   | 3/32                                            |
| 3 .....             | 1                                     | 1/8                               | 3/16    | 3/16                                  | 3/32                                            |
| 4 .....             | 1 3/8                                 | 1/8                               | 3/16    | 3/16                                  | 1/8                                             |
| 5 .....             | 1 3/4                                 | 3/16                              | 1/4     | 1/4                                   | 1/8                                             |
| 6 .....             | 2                                     | 1/4                               | 1/2     | 3/8                                   | 3/16                                            |
| 7 .....             | 2 1/2                                 | 1/4                               | 1/2     | 3/8                                   | 3/16                                            |
| 8 .....             | 3                                     | 1/4                               | 1/2     | 3/8                                   | 3/16                                            |
| 10 .....            | 3 1/2                                 | 5/16                              | 5/8     | 3/8                                   | 1/4                                             |
| 12 .....            | 4                                     | 5/16                              | 5/8     | 1/2                                   | 5/16                                            |
| 14 .....            | 4 1/2                                 | 3/8                               | 3/4     | 1/2                                   | 5/16                                            |
| 16 .....            | 5 1/2                                 | 1/2                               | 1       | 1/2                                   | 5/16                                            |
| 18 .....            | 6                                     | 1/2                               | 1       | 5/8                                   | 3/8                                             |
| 20 .....            | 7                                     | 5/8                               | 1 1/4   | 5/8                                   | 3/8                                             |
| 22 .....            | 7 1/2                                 | 5/8                               | 1 1/4   | 5/8                                   | 7/16                                            |
| 24 .....            | 8                                     | 3/4                               | 1 1/4   | 5/8                                   | 7/16                                            |
| 26 .....            | 8 1/2                                 | 3/4                               | 1 1/4   | 5/8                                   | 1/2                                             |
| 28 .....            | 10                                    | 7/8                               | 1 1/2   | 3/4                                   | 1/2                                             |
| 30 .....            | 10                                    | 7/8                               | 1 1/2   | 3/4                                   | 5/8                                             |
| 36 .....            | 12                                    | 1                                 | 2       | 7/8                                   | 3/4                                             |
| 42 .....            | 14                                    | 1                                 | 2       | 7/8                                   | 3/4                                             |
| 48 .....            | 16                                    | 1 1/4                             | 2       | 1 1/8                                 | 1                                               |
| 60 .....            | 20                                    | 1 1/4                             | 2       | 1 1/4                                 | 1 1/8                                           |
| 72 .....            | 24                                    | 1 1/2                             | 2 1/2   | 1 3/8                                 | 1 1/4                                           |

<sup>1</sup>Flanges for wheels under 2 inches diameter may be unrelieved and shall be maintained flat and true.

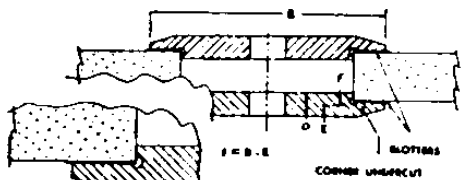

**FIGURE NO. O-33**  
Central Nut Mounting  
Driving flange secured to spindle.

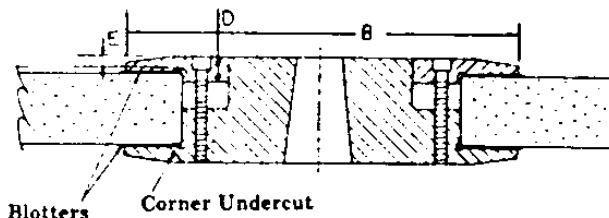

**FIGURE NO. O-34**  
Multiple Screw Mounting  
Driving flange secured to spindle.

TABLE O-7--MINIMUM DIMENSIONS FOR STRAIGHT FLANGES--FOR MECHANICAL GRINDERS  
12,500 S.F.P.M. TO 16,5 S.F.P.M<sup>1</sup>

| Wheel diameter | Wheel hole diameter | B-Minimum flange diameter | D-Minimum thickness of flange at bore | E-Minimum thickness of flange at edge of undercut | F <sup>2</sup> -(D-E) minimum thickness |
|----------------|---------------------|---------------------------|---------------------------------------|---------------------------------------------------|-----------------------------------------|
| 20             | 6                   | 8                         | 1                                     | 1/2                                               | 1/2                                     |
| 20             | 8                   | 10                        | 1 1/2                                 | 3/4                                               | 3/4                                     |
| 24             | 12                  | 15                        | 2                                     | 1                                                 | 1                                       |
| 30             | 12                  | 15                        | 2                                     | 1                                                 | 1                                       |
| 36             | 12                  | 15                        | 2                                     | 1                                                 | 1                                       |

<sup>1</sup>Flanges shall be of steel, quality SAE 1040 or equivalent, annealed plate, heat treated to R.25-30.

<sup>2</sup>For wheels under 1 1/4 inch thick F dimension shall not exceed 40 percent of wheel thickness.

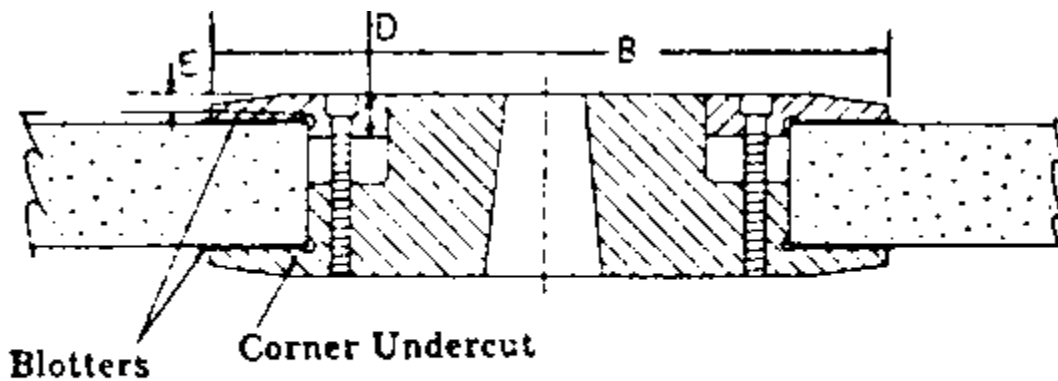

**FIGURE NO. O-35**

*Driving flange secured to spindle.*

TABLE O-8--MINIMUM DIMENSIONS FOR STRAIGHT FLANGES USED AS WHEEL SLEEVES FOR PRECISION GRINDING ONLY  
[In inches]

| Wheel diameter            | Wheel hole diameter | B-Minimum outside diameter of flange | D-Minimum thickness of flange at bore | E-Minimum thickness of flange at edge of undercut |
|---------------------------|---------------------|--------------------------------------|---------------------------------------|---------------------------------------------------|
| 12 to 14 .....            | 5                   | 7                                    | 1/2                                   | 7/16                                              |
| Larger than 14 to 20..... | 5                   | 7                                    | 5/8                                   | 7/16                                              |
|                           | 6                   | 8                                    | 5/8                                   | 7/16                                              |
|                           | 8                   | 10                                   | 5/8                                   | 7/16                                              |
|                           | 10                  | 11 1/2                               | 5/8                                   | 7/16                                              |
|                           | 12                  | 13 1/2                               | 5/8                                   | 7/16                                              |
| Larger than 20 to 30..... | 8                   | 10                                   | 3/4                                   | 1/2                                               |
|                           | 10                  | 11 1/2                               | 3/4                                   | 1/2                                               |
|                           | 12                  | 13 1/2                               | 3/4                                   | 1/2                                               |
|                           | 16                  | 17 1/2                               | 3/4                                   | 1/2                                               |
| Larger than 30 to 42..... | 12                  | 13 1/2                               | 3/4                                   | 1/2                                               |
|                           | 16                  | 17 1/2                               | 3/4                                   | 1/2                                               |
|                           | 18                  | 19 1/2                               | 3/4                                   | 1/2                                               |
| Larger than 42 to 60..... | 20                  | 21 1/2                               | 3/4                                   | 1/2                                               |
|                           | 16                  | 20                                   | 1                                     | 3/4                                               |
|                           | 20                  | 24                                   | 1                                     | 3/4                                               |
|                           | 24                  | 29                                   | 1 1/8                                 | 7/8                                               |

NOTE: These flanges may be clamped together by means of a central nut, or by a series of bolts or some other equivalent means of fastening. For hole sizes smaller than shown in this table, use table 12.

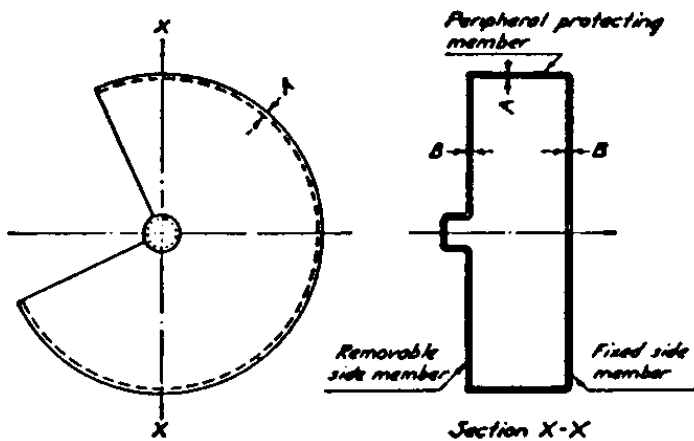

FIGURE NO. O-36

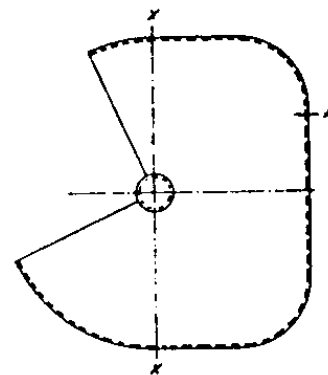

FIGURE NO. O-37

TABLE O-9--MINIMUM BASIC THICKNESS OF PERIPHERAL AND SIDE MEMBERS FOR SAFETY GUARDS  
[In inches]

| Material used in construction of guard                                                                                                  | Maximum thickness of grinding wheel | Grinding wheel diameter |      |                     |       |                      |       |
|-----------------------------------------------------------------------------------------------------------------------------------------|-------------------------------------|-------------------------|------|---------------------|-------|----------------------|-------|
|                                                                                                                                         |                                     | 3 to 6 inches           |      | Over 6 to 12 inches |       | Over 12 to 16 inches |       |
|                                                                                                                                         |                                     | A                       | B    | A                   | B     | A                    | B     |
| Material satisfactory <sup>1</sup> for speeds up to 8,000 SFPM.<br>Cast iron (min. tensile strength 20,000 p.s.i.) Class 20.            | 2                                   | 1/4                     | 1/4  | 3/8                 | 5/16  | 1/2                  | 3/8   |
|                                                                                                                                         | 4                                   | 5/16                    | 5/16 | 3/8                 | 5/16  | 1/2                  | 3/8   |
|                                                                                                                                         | 6                                   | 3/8                     | 5/16 | 1/2                 | 7/16  | 5/8                  | 1/2   |
|                                                                                                                                         | 8                                   |                         |      | 5/8                 | 9/16  | 7/8                  | 3/4   |
|                                                                                                                                         | 10                                  |                         |      | 3/4                 | 11/16 | 7/8                  | 3/4   |
|                                                                                                                                         | 16                                  |                         |      |                     |       | 1 1/8                | 1     |
|                                                                                                                                         | 20                                  |                         |      |                     |       |                      |       |
| Material satisfactory <sup>1</sup> for speeds up to 9,000 SFPM.<br>Malleable iron (min. tensile strength 50,000 p.s.i.) Grade 32510.    | 2                                   | 1/4                     | 1/4  | 3/8                 | 5/16  | 1/2                  | 3/8   |
|                                                                                                                                         | 4                                   | 5/16                    | 5/16 | 3/8                 | 5/16  | 1/2                  | 3/8   |
|                                                                                                                                         | 6                                   | 3/8                     | 5/16 | 1/2                 | 7/16  | 5/8                  | 1/2   |
|                                                                                                                                         | 8                                   |                         |      | 1/2                 | 7/16  | 5/8                  | 1/2   |
|                                                                                                                                         | 10                                  |                         |      | 1/2                 | 7/16  | 5/8                  | 1/2   |
|                                                                                                                                         | 16                                  |                         |      |                     |       | 13/16                | 11/16 |
|                                                                                                                                         | 20                                  |                         |      |                     |       |                      |       |
| Materials satisfactory <sup>1</sup> for speeds up to 16,000 SFPM.<br>Steel castings (min. tensile strength 60,000 p.s.i.) Grade V60-30. | 2                                   | 1/4                     | 1/4  | 5/16                | 5/16  | 3/8                  | 3/8   |
|                                                                                                                                         | 4                                   | 1/4                     | 1/4  | 1/2                 | 1/2   | 1/2                  | 1/2   |
|                                                                                                                                         | 6                                   | 3/8                     | 1/4  | 3/4                 | 5/8   | 3/4                  | 5/8   |
|                                                                                                                                         | 8                                   |                         |      | 7/8                 | 3/4   | 7/8                  | 3/4   |
|                                                                                                                                         | 10                                  |                         |      | 1                   | 7/8   | 1                    | 7/8   |
|                                                                                                                                         | 16                                  |                         |      |                     |       | 1 1/4                | 1 1/8 |
|                                                                                                                                         | 20                                  |                         |      |                     |       |                      |       |
| Structural steel (min. tensile strength 60,000 p.s.i.)                                                                                  | 2                                   | 1/8                     | 1/16 | 5/16                | 1/4   | 5/16                 | 1/4   |
|                                                                                                                                         | 4                                   | 1/8                     | 1/16 | 3/8                 | 5/16  | 3/8                  | 5/16  |
|                                                                                                                                         | 6                                   | 3/16                    | 1/16 | 1/2                 | 3/8   | 7/16                 | 3/8   |
|                                                                                                                                         | 8                                   |                         |      | 1/2                 | 3/8   | 9/16                 | 7/16  |
|                                                                                                                                         | 10                                  | 9/16                    | 7/16 | 5/8                 | 1/2   | 5/8                  | 1/2   |
|                                                                                                                                         | 16                                  |                         |      |                     |       | 5/8                  | 9/16  |
|                                                                                                                                         | 20                                  |                         |      |                     |       |                      |       |

<sup>1</sup>The recommendations listed in the above table are guides for the conditions stated. Other material, designs or dimensions affording equal or superior protection are also acceptable.

TABLE O-9--MINIMUM BASIC THICKNESS OF PERIPHERAL AND SIDE MEMBERS FOR SAFETY GUARDS  
 [In inches]-Continued

| Material used in construction of guard                                                                                               | Maximum thickness of grinding wheel | Grinding wheel diameter |       |                      |       |                      |        |                      |        |
|--------------------------------------------------------------------------------------------------------------------------------------|-------------------------------------|-------------------------|-------|----------------------|-------|----------------------|--------|----------------------|--------|
|                                                                                                                                      |                                     | Over 16 to 20 inches    |       | Over 20 to 24 inches |       | Over 24 to 30 inches |        | Over 30 to 48 inches |        |
|                                                                                                                                      |                                     | A                       | B     | A                    | B     | A                    | B      | A                    | B      |
| Material satisfactory <sup>1</sup> for speeds up to 8,000 SFPM. Cast iron (min. tensile strength 20,000 p.s.i.) Class 20.            | 2                                   | 5/8                     | 1/2   | 7/8                  | 5/8   | 1                    | 3/4    | 1 1/4                | 1      |
|                                                                                                                                      | 4                                   | 3/4                     | 5/8   | 1                    | 5/8   | 1 1/8                | 3/4    | 1 3/8                | 1      |
|                                                                                                                                      | 6                                   | 1                       | 5/8   | 1 1/8                | 3/4   | 1 1/4                | 7/8    | 1 1/2                | 1 1/8  |
|                                                                                                                                      | 8                                   | 1                       | 3/4   | 1 1/8                | 3/4   | 1 1/4                | 7/8    | 1 1/2                | 1 1/8  |
|                                                                                                                                      | 10                                  | 1                       | 3/4   | 1 1/8                | 3/4   | 1 1/4                | 7/8    | 1 1/2                | 1 1/8  |
|                                                                                                                                      | 16                                  | 1 1/4                   | 1     | 1 5/16               | 1     | 1 7/16               | 1 1/16 | 1 3/4                | 1 3/8  |
| Material satisfactory <sup>1</sup> for speeds up to 9,000 SFPM. Malleable iron (min. tensile strength 50,000 p.s.i.) Grade 32510.    | 2                                   | 5/8                     | 1/2   | 3/4                  | 5/8   | 7/8                  | 3/4    | 1                    | 7/8    |
|                                                                                                                                      | 4                                   | 5/8                     | 1/2   | 3/4                  | 5/8   | 7/8                  | 3/4    | 1 1/8                | 7/8    |
|                                                                                                                                      | 6                                   | 3/4                     | 5/8   | 7/8                  | 5/8   | 1                    | 3/4    | 1 1/4                | 7/8    |
|                                                                                                                                      | 8                                   | 3/4                     | 5/8   | 7/8                  | 5/8   | 1                    | 3/4    | 1 1/4                | 7/8    |
|                                                                                                                                      | 10                                  | 3/4                     | 5/8   | 7/8                  | 5/8   | 1                    | 3/4    | 1 1/4                | 7/8    |
|                                                                                                                                      | 16                                  | 13/16                   | 11/16 | 1                    | 3/4   | 1 1/8                | 7/8    | 1 3/8                | 1      |
| Materials satisfactory <sup>1</sup> for speeds up to 16,000 SFPM. Steel castings (min. tensile strength 60,000 p.s.i.) Grade V60-30. | 2                                   | 1/2                     | 7/16  | 5/8                  | 1/2   | 3/4                  | 5/8    | 7/8                  | 3/4    |
|                                                                                                                                      | 4                                   | 9/16                    | 1/2   | 5/8                  | 1/2   | 3/4                  | 5/8    | 1                    | 3/4    |
|                                                                                                                                      | 6                                   | 3/4                     | 5/8   | 13/16                | 11/16 | 13/16                | 11/16  | 1 1/8                | 3/4    |
|                                                                                                                                      | 8                                   | 7/8                     | 3/4   | 7/8                  | 3/4   | 15/16                | 13/16  | 1 3/8                | 1      |
|                                                                                                                                      | 10                                  | 1                       | 7/8   | 1 1/8                | 15/16 | 1 1/8                | 1      | 1 7/16               | 1 1/16 |
|                                                                                                                                      | 16                                  | 1 1/4                   | 1 1/8 | 1 1/4                | 1 1/8 | 1 1/4                | 1 1/8  | 1                    | 1 7/16 |
| Structural steel (min. tensile strength 60,000 p.s.i.)                                                                               | 2                                   | 5/16                    | 1/4   | 5/16                 | 1/4   | 3/8                  | 5/16   | 1/2                  | 3/8    |
|                                                                                                                                      | 4                                   | 3/8                     | 5/16  | 3/8                  | 5/16  | 3/8                  | 5/16   | 1/2                  | 3/8    |
|                                                                                                                                      | 6                                   | 7/16                    | 3/8   | 7/16                 | 3/8   | 7/16                 | 3/8    | 3/4                  | 1/2    |
|                                                                                                                                      | 8                                   | 9/16                    | 7/16  | 9                    |       |                      |        |                      |        |
|                                                                                                                                      | 10                                  | 5/8                     | 1/2   | 5/8                  | 1/2   | 7/8                  | 5/8    |                      |        |
|                                                                                                                                      | 16                                  | 3/4                     | 5/8   | 3/4                  | 5/8   | 13/16                | 11/16  | 1 1/16               | 13/16  |
| 20                                                                                                                                   | 13/16                               | 11/16                   | 13/16 | 11/16                | 7/8   | 3/4                  | 1 3/16 | 15/16                |        |

<sup>1</sup>The recommendations listed in the above table are guides for the conditions stated. Other material, designs or dimensions affording equal or superior protection are also acceptable.

TABLE O-2--EXPOSURE VERSUS WHEEL THICKNESS  
[in inches]

| Overall thickness of wheel (T) | Maximum exposure of wheel (C) |
|--------------------------------|-------------------------------|
| 1/2 .....                      | 1/4                           |
| 1 .....                        | 1/2                           |
| 2 .....                        | 3/4                           |
| 3 .....                        | 1                             |
| 4 .....                        | 1 1/2                         |
| 5 and over .....               | 2                             |

TABLE O-4--MINIMUM DIMENSIONS FOR STRAIGHT UNRELIEVED FLANGES FOR WHEELS WITH THREADED INSERTS OR PROJECTING STUDS

| A-Diameter of wheel | B <sup>1</sup> -Minimum outside diameter of flange | T-Minimum thickness of flange |
|---------------------|----------------------------------------------------|-------------------------------|
| 1                   | 5/8                                                | 1/8                           |
| 2                   | 1                                                  | 1/8                           |
| 3                   | 1                                                  | 3/16                          |
| 4                   | 1 3/8                                              | 3/16                          |
| 5                   | 1 3/4                                              | 1/4                           |
| 6                   | 2                                                  | 3/8                           |

<sup>1</sup>NOTE: Must be large enough to extend beyond the bushing. Where prong anchor or cupback bushing are used, this footnote does not apply.

**§1910.216 Mills and calenders in the rubber and plastics industries.**

**(a) General requirements.**

- (1) [Reserved]
- (2) [Reserved]
- (3) Auxiliary equipment. Mechanical and electrical equipment and auxiliaries shall be installed in accordance with this section and Subpart S of this part.
- (4) Mill roll heights. All new mill installations shall be installed so that the top of the operating rolls is not less than 50 inches above the level on which the operator stands, irrespective of the size of the mill. This distance shall apply to the actual working level, whether it be at the general floor level, in a pit, or on a platform.

**(b) Mill safety controls.**

- (1) Safety trip control. A safety trip control shall be provided in front and in back of each mill. It shall be accessible and shall operate readily on contact. The safety trip control shall be one of the following types or a combination thereof:
  - (i) Pressure-sensitive body bars. Installed at front and back of each mill having a 46-inch roll height or over. These bars shall operate readily by pressure of the mill operator's body.
  - (ii) Safety triprod. Installed in the front and in the back of each mill and located within 2 inches of a vertical plane tangent to the front and rear rolls. The top rods shall be not more than 72 inches above the level on which the operator stands. The triprods shall be accessible and shall operate readily whether the rods are pushed or pulled.

- (iii) Safety tripwire cable or wire center cord. Installed in the front and in the back of each mill and located within 2 inches of a vertical plane tangent to the front and rear rolls. The cables shall not be more than 72 inches above the level on which the operator stands. The tripwire cable or wire center cord shall operate readily whether cable or cord is pushed or pulled.
- (2) [Reserved]
- (3) Auxiliary equipment. All auxiliary equipment such as mill divider, support bars, spray pipes, feed conveyors, strip knives, etc., shall be located in such a manner as to avoid interference with access to and operation of safety devices.
- (c) Calender safety controls.
  - (1) Safety trip, face. A safety triprod, cable, or wire center cord shall be provided across each pair of in-running rolls extending the length of the face of the rolls. It shall be readily accessible and operate whether pushed or pulled. The safety tripping devices shall be located within reach of the operator and the bite.
  - (2) Safety trip, side. On both sides of the calender and near each end of the face of the roll, there shall be a cable or wire center cord connected to the safety trip. They shall operate readily when pushed or pulled.
- (d) Protection by location.
  - (1) Mills. Where a mill is so installed that persons cannot normally reach through, over, under, or around to come in contact with the roll bite or be caught between a roll and an adjacent object, then, provided such elements are made a fixed part of a mill, safety control devices listed in paragraph (b) of this section shall not apply.
  - (2) Calenders. Where a calender is so installed that persons cannot normally reach through, over, under, or around to come in contact with the roll bite or be caught between a roll and an adjacent object, then, provided such elements are made a fixed part of a calender, safety control devices listed in paragraph (c) of this section shall not apply.
- (e) Trip and emergency switches. All trip and emergency switches shall not be of the automatically resetting type, but shall require manual resetting.
- (f) Stopping limits.
  - (1) Determination of distance of travel. All measurements on mills and calenders shall be taken with the rolls running empty at maximum operating speed. Stopping distances shall be expressed in inches of surface travel of the roll from the instant the emergency stopping device is actuated.
  - (2) Stopping limits for mills. All mills irrespective of the size of the rolls or their arrangement (individually or group-driven) shall be stopped within a distance, as measured in inches of surface travel, not greater than 1 1/2 percent of the peripheral no-load surface speeds of the respective rolls as determined in feet per minute.
  - (3) Stopping limits for calenders.
    - (i) All calenders, irrespective of size of the rolls or their configuration, shall be stopped within a distance, as measured in inches of surface travel, not greater than 1 3/4 percent of the peripheral no-load surface speeds of the respective calender rolls as determined in feet per minute.
    - (ii) Where speeds above 250 feet per minute as measured on the surface of the drive roll are used, stopping distances of more than 1 3/4 percent are permissible. Such stopping distances shall be subject to engineering determination.

#### **§1910.217 Mechanical power presses.**

- (a) General requirements.
  - (1) [Reserved]
  - (2) [Reserved]
  - (3) [Reserved]
  - (4) Reconstruction and modification. It shall be the responsibility of any person reconstructing, or modifying a mechanical power press to do so in accordance with paragraph (b) of this section.
  - (5) Excluded machines. Press brakes, hydraulic and pneumatic power presses, bulldozers, hot bending and hot metal presses, forging presses and hammers, riveting machines and similar types of fastener applicators are excluded from the requirements of this section.

- (b) Mechanical power press guarding and construction, general.**
- (1) Hazards to personnel associated with broken or falling machine components. Machine components shall be designed, secured, or covered to minimize hazards caused by breakage, or loosening and falling or release of mechanical energy (i.e. broken springs).
  - (2) Brakes. Friction brakes provided for stopping or holding a slide movement shall be inherently self-engaging by requiring power or force from an external source to cause disengagement. Brake capacity shall be sufficient to stop the motion of the slide quickly and capable of holding the slide and its attachments at any point in its travel.
  - (3) Machines using full revolution positive clutches.
    - (i) Machines using full revolution clutches shall incorporate a single-stroke mechanism.
    - (ii) If the single-stroke mechanism is dependent upon spring action, the spring(s) shall be of the compression type, operating on a rod or guided within a hole or tube, and designed to prevent interleaving of the spring coils in event of breakage.
  - (4) Foot pedals (treadle).
    - (i) The pedal mechanism shall be protected to prevent unintended operation from falling or moving objects or by accidental stepping onto the pedal.
    - (ii) A pad with a nonslip contact area shall be firmly attached to the pedal.
    - (iii) The pedal return spring(s) shall be of the compression type, operating on a rod or guided within a hole or tube, or designed to prevent interleaving of spring coils in event of breakage.
    - (iv) If pedal counterweights are provided, the path of the travel of the weight shall be enclosed.
  - (5) Hand operated levers.
    - (i) Hand-lever-operated power presses shall be equipped with a spring latch on the operating lever to prevent premature or accidental tripping.
    - (ii) The operating levers on hand-tripped presses having more than one operating station shall be interlocked to prevent the tripping of the press except by the "concurrent" use of all levers.
  - (6) Two-hand trip.
    - (i) A two-hand trip shall have the individual operator's hand controls protected against unintentional operation and have the individual operator's hand controls arranged by design and construction and/or separation to require the use of both hands to trip the press and use a control arrangement requiring concurrent operation of the individual operator's hand controls.
    - (ii) Two-hand trip systems on full revolution clutch machines shall incorporate an antirepeat feature.
    - (iii) If two-hand trip systems are used on multiple operator presses, each operator shall have a separate set of controls.
  - (7) Machines using part revolution clutches.
    - (i) The clutch shall release and the brake shall be applied when the external clutch engaging means is removed, deactivated, or deenergized.
    - (ii) A red color stop control shall be provided with the clutch/brake control system. Momentary operation of the stop control shall immediately deactivate the clutch and apply the brake. The stop control shall override any other control, and reactivation of the clutch shall require use of the operating (tripping) means which has been selected.
    - (iii) A means of selecting Off, "Inch," Single Stroke, and Continuous (when the continuous function is furnished) shall be supplied with the clutch/brake control to select type of operation of the press. Fixing of selection shall be by means capable of supervision by the employer.
    - (iv) The "Inch" operating means shall be designed to prevent exposure of the workers hands within the point of operation by:
      - (a) Requiring the concurrent use of both hands to actuate the clutch, or
      - (b) Being a single control protected against accidental actuation and so located that the worker cannot reach into the point of operation while operating the single control.
    - (v) Two-hand controls for single stroke shall conform to the following requirements:

- (a) Each hand control shall be protected against unintended operation and arranged by design, construction, and/or separation so that the concurrent use of both hands is required to trip the press.
- (b) The control system shall be designed to permit an adjustment which will require concurrent pressure from both hands during the die closing portion of the stroke.
- (c) The control system shall incorporate an antirepeat feature.
- (d) The control systems shall be designed to require release of all operators' hand controls before an interrupted stroke can be resumed. This requirement pertains only to those single-stroke, two-hand controls manufactured and installed on or after August 31, 1971.
- (vi) [Reserved]
- (vii) Controls for more than one operating station shall be designed to be activated and deactivated in complete sets of two operator's hand controls per operating station by means capable of being supervised by the employer. The clutch/brake control system shall be designed and constructed to prevent actuation of the clutch if all operating stations are bypassed.
- (viii) Those clutch/brake control systems which contain both single and continuous functions shall be designed so that completion of continuous circuits may be supervised by the employer. The initiation of continuous run shall require a prior action or decision by the operator in addition to the selection of Continuous on the stroking selector, before actuation of the operating means will result in continuous stroking.
- (ix) If foot control is provided, the selection method between hand and foot control shall be separate from the stroking selector and shall be designed so that the selection may be supervised by the employer.
- (x) Foot operated tripping controls, if used, shall be protected so as to prevent operation from falling or moving objects, or from unintended operation by accidental stepping onto the foot control.
- (xi) The control of air-clutch machines shall be designed to prevent a significant increase in the normal stopping time due to a failure within the operating value mechanism, and to inhibit further operation if such failure does occur. This requirement shall apply only to those clutch/brake air-valve controls manufactured and installed on or after August 31, 1971, but shall not apply to machines intended only for continuous, automatic feeding applications.
- (xii) The clutch/brake control shall incorporate an automatic means to prevent initiation or continued activation of the Single Stroke or Continuous functions unless the press drive motor is energized and in the forward direction.
- (xiii) The clutch/brake control shall automatically deactivate in event of failure of the power or pressure supply for the clutch engaging means. Reactivation of the clutch shall require restoration of normal supply and the use of the tripping mechanism(s).
- (xiv) The clutch/brake control shall automatically deactivate in event of failure of the counterbalance(s) air supply. Reactivation of the clutch shall require restoration of normal air supply and use of the tripping mechanism(s).
- (xv) Selection of bar operation shall be by means capable of being supervised by the employer. A separate pushbutton shall be employed to activate the clutch, and the clutch shall be activated only if the driver motor is deenergized.
- (8) Electrical.
  - (i) A main power disconnect switch capable of being locked only in the Off position shall be provided with every power press control system.
  - (ii) The motor start button shall be protected against accidental operation.
  - (iii) All mechanical power press controls shall incorporate a type of drive motor starter that will disconnect the drive motor from the power source in event of control voltage or power source failure, and require operation of the motor start button to restart the motor when voltage conditions are restored to normal.
  - (iv) All a.c. control circuits and solenoid valve coils shall be powered by not more than a nominal 120-volt a.c. supply obtained from a transformer with an isolated secondary. Higher voltages that may be necessary for operation of machine or control mechanisms shall be isolated from any control mechanism handled by the operator, but motor starters with

- integral Start-Stop buttons may utilize line voltage control. All d.c. control circuits shall be powered by not more than a nominal 240-volt d.c. supply isolated from any higher voltages.
- (v) All clutch/brake control electrical circuits shall be protected against the possibility of an accidental ground in the control circuit causing false operation of the press.
  - (vi) Electrical clutch/brake control circuits shall incorporate features to minimize the possibility of an unintended stroke in the event of the failure of a control component to function properly, including relays, limit switches, and static output circuits.
- (9) Slide counterbalance systems.
- (i) Spring counterbalance systems when used shall incorporate means to retain system parts in event of breakage.
  - (ii) Spring counterbalances when used shall have the capability to hold the slide and its attachments at midstroke, without brake applied.
  - (iii) Air counterbalance cylinders shall incorporate means to retain the piston and rod in case of breakage or loosening.
  - (iv) Air counterbalance cylinders shall have adequate capability to hold the slide and its attachments at any point in stroke, without brake applied.
  - (v) Air counterbalance cylinders shall incorporate means to prevent failure of capability (sudden loss of pressure) in event of air supply failure.
- (10) Air controlling equipment. Air controlling equipment shall be protected against foreign material and water entering the pneumatic system of the press. A means of air lubrication shall be provided when needed.
- (11) Hydraulic equipment. The maximum anticipated working pressures in any hydraulic system on a mechanical power press shall not exceed the safe working pressure rating of any component used in that system.
- (12) Pressure vessels. All pressure vessels used in conjunction with power presses shall conform to the American Society of Mechanical Engineers Code for Pressure Vessels, 1968 Edition, which is incorporated by reference as specified in §1910.6.
- (13) Control reliability. When required by paragraph (c)(5) of this section, the control system shall be constructed so that a failure within the system does not prevent the normal stopping action from being applied to the press when required, but does prevent initiation of a successive stroke until the failure is corrected. The failure shall be detectable by a simple test, or indicated by the control system. This requirement does not apply to those elements of the control system which have no effect on the protection against point of operation injuries.
- (14) Brake system monitoring. When required by paragraph (c)(5) of this section, the brake monitor shall meet the following requirements:
- (i) Be so constructed as to automatically prevent the activation of a successive stroke if the stopping time or braking distance deteriorates to a point where the safety distance being utilized does not meet the requirements set forth in paragraph (c)(3)(iii)(e) or (c)(3)(vii)(c) of this section. The brake monitor used with the Type B gate or movable barrier device shall be installed in a manner to detect slide top-stop overrun beyond the normal limit reasonably established by the employer.
  - (ii) Be installed on a press such that it indicates when the performance of the braking system has deteriorated to the extent described in paragraph (b)(14)(i) of this section; and
  - (iii) Be constructed and installed in a manner to monitor brake system performance on each stroke.
- (c) Safeguarding the point of operation.
- (1) General requirements.
    - (i) It shall be the responsibility of the employer to provide and insure the usage of "point of operation guards" or properly applied and adjusted point of operation devices on every operation performed on a mechanical power press. See Table O-10.
    - (ii) The requirement of paragraph (c)(1)(i) of this section shall not apply when the point of operation opening is one-fourth inch or less. See Table O-10.
  - (2) Point of operation guards.
    - (i) Every point of operation guard shall meet the following design, construction, application, and adjustment requirements:

- (a) It shall prevent entry of hands or fingers into the point of operation by reaching through, over, under or around the guard;
  - (b) It shall conform to the maximum permissible openings of Table O-10;
  - (c) It shall, in itself, create no pinch point between the guard and moving machine parts;
  - (d) It shall utilize fasteners not readily removable by operator, so as to minimize the possibility of misuse or removal of essential parts;
  - (e) It shall facilitate its inspection, and
  - (f) It shall offer maximum visibility of the point of operation consistent with the other requirements.
  - (ii) A die enclosure guard shall be attached to the die shoe or stripper in a fixed position.
  - (iii) A fixed barrier guard shall be attached securely to the frame of the press or to the bolster plate.
  - (iv) An interlocked press barrier guard shall be attached to the press frame or bolster and shall be interlocked with the press clutch control so that the clutch cannot be activated unless the guard itself, or the hinged or movable sections of the guard are in position to conform to the requirements of Table O-10.
  - (v) The hinged or movable sections of an interlocked press barrier guard shall not be used for manual feeding. The guard shall prevent opening of the interlocked section and reaching into the point of operation prior to die closure or prior to the cessation of slide motion. See paragraph (c)(3)(ii) of this section regarding manual feeding through interlocked press barrier devices.
  - (vi) The adjustable barrier guard shall be securely attached to the press bed, bolster plate, or die shoe, and shall be adjusted and operated in conformity with Table O-10 and the requirements of this subparagraph. Adjustments shall be made only by authorized personnel whose qualifications include a knowledge of the provisions of Table O-10 and this subparagraph.
  - (vii) A point of operation enclosure which does not meet the requirements of this subparagraph and Table O-10 shall be used only in conjunction with point of operation devices.
- (3) Point of operation devices.
- (i) Point of operation devices shall protect the operator by:
    - (a) Preventing and/or stopping normal stroking of the press if the operator's hands are inadvertently placed in the point of operation; or
    - (b) Preventing the operator from inadvertently reaching into the point of operation, or withdrawing his hands if they are inadvertently located in the point of operation, as the dies close; or
    - (c) Preventing the operator from inadvertently reaching into the point of operation at all times; or
    - (d) [Reserved]
    - (e) Requiring application of both of the operator's hands to machine operating controls and locating such controls at such a safety distance from the point of operation that the slide completes the downward travel or stops before the operator can reach into the point of operation with his hands; or
    - (f) Enclosing the point of operation before a press stroke can be initiated, and maintaining this closed condition until the motion of the slide had ceased; or
    - (g) Enclosing the point of operation before a press stroke can be initiated, so as to prevent an operator from reaching into the point of operation prior to die closure or prior to cessation of slide motion during the downward stroke.
  - (ii) A gate or movable barrier device shall protect the operator as follows:
    - (a) A Type A gate or movable barrier device shall protect the operator in the manner specified in paragraph (c)(3)(i)(f) of this section, and
    - (b) A Type B gate or movable barrier device shall protect the operator in the manner specified in paragraph (c)(3)(i)(g) of this section.
  - (iii) A presence sensing point of operation device shall protect the operator as provided in paragraph (c)(3)(i)(a) of this section, and shall be interlocked into the control circuit to prevent or stop slide motion if the operator's hand or other part of his body is within the sensing field of the device during the downstroke of the press slide.

- (a) The device may not be used on machines using full revolution clutches.
- (b) The device may not be used as a tripping means to initiate slide motion, except when used in total conformance with paragraph (h) of this section.
- (c) The device shall be constructed so that a failure within the system does not prevent the normal stopping action from being applied to the press when required, but does prevent the initiation of a successive stroke until the failure is corrected. The failure shall be indicated by the system.
- (d) Muting (bypassing of the protective function) of such device, during the upstroke of the press slide, is permitted for the purpose of parts ejection, circuit checking, and feeding.
- (e) The safety distance ( $D_s$ ) from the sensing field to the point of operation shall be greater than the distance determined by the following formula:

$$D_s = 63 \text{ inches/second} \times T_s$$

where:

$D_s$  = minimum safety distance (inches); 63 inches/second=hand speed constant; and  
 $T_s$  = stopping time of the press measured at approximately 90° position of crankshaft rotation (seconds).

- (f) Guards shall be used to protect all areas of entry to the point of operation not protected by the presence sensing device.
- (iv) The pull-out device shall protect the operator as specified in paragraph (c)(3)(i)(b) of this section, and shall include attachments for each of the operator's hands.
  - (a) Attachments shall be connected to and operated only by the press slide or upper die.
  - (b) Attachments shall be adjusted to prevent the operator from reaching into the point of operation or to withdraw the operator's hands from the point of operation before the dies close.
  - (c) A separate pull-out device shall be provided for each operator if more than one operator is used on a press.
  - (d) Each pull-out device in use shall be visually inspected and checked for proper adjustment at the start of each operator shift, following a new die set-up, and when operators are changed. Necessary maintenance or repair or both shall be performed and completed before the press is operated. Records of inspections and maintenance shall be kept in accordance with paragraph (e) of this section.
- (v) The sweep device may not be used for point of operation safeguarding.
- (vi) A holdout or a restraint device shall protect the operator as specified in paragraph (c)(3)(i)(c) of this section and shall include attachments for each of the operator's hands. Such attachments shall be securely anchored and adjusted in such a way that the operator is restrained from reaching into the point of operation. A separate set of restraints shall be provided for each operator if more than one operator is required on a press.
- (vii) The two hand control device shall protect the operator as specified in paragraph (c)(3)(i)(e) of this section.
  - (a) When used in press operations requiring more than one operator, separate two hand controls shall be provided for each operator, and shall be designed to require concurrent application of all operators' controls to activate the slide. The removal of a hand from any control button shall cause the slide to stop.
  - (b) Each two hand control shall meet the construction requirements of paragraph (b)(7)(v) of this section.
  - (c) The safety distance ( $D_s$ ) between each two hand control device and the point of operation shall be greater than the distance determined by the following formula:

$$D_2 = 63 \text{ inches/second} \times T_s;$$

where:

$D_s$  = minimum safety distance (inches); 63 inches/second=hand speed constant;  
 and

$T_s$  = stopping time of the press measured at approximately 90° position of crankshaft rotation (seconds).

- (d) Two hand controls shall be fixed in position so that only a supervisor or safety engineer is capable of relocating the controls.
- (viii) The two hand trip device shall protect the operator as specified in paragraph (c)(3)(i)(e) of this section.
- (a) When used in press operations requiring more than one operator, separate two hand trips shall be provided for each operator, and shall be designed to require concurrent application of all operators' to activate the slide.
  - (b) Each two hand trip shall meet the construction requirements of paragraph (b)(6) of this section.
  - (c) The safety distance ( $D_m$ ) between the two hand trip and the point of operation shall be greater than the distance determined by the following formula:
 

$D_m = 63 \text{ inches/second} \times T_m$ ;

where:

$D_m$  = minimum safety distance (inches); 63 inches/second=hand speed constant;

and

$T_m$  = the maximum time the press takes for the die closure after it has been tripped (seconds). For full revolution clutch presses with only one engaging point  $T_m$  is equal to the time necessary for one and one-half revolutions of the crankshaft. For full revolution clutch presses with more than one engaging point,  $T_m$  shall be calculated as follows:

$T_m = [1/2 + (1 \square \text{ Number of engaging points per revolution})] \times \text{time necessary to complete one revolution of the crankshaft (seconds)}$ .
  - (d) Two hand trips shall be fixed in position so that only a supervisor or safety engineer is capable of relocating the controls.
- (4) Hand feeding tools. Hand feeding tools are intended for placing and removing materials in and from the press. Hand feeding tools are not a point of operation guard or protection device and shall not be used in lieu of the "guards" or devices required in this section.
- (5) Additional requirements for safe-guarding. Where the operator feeds or removes parts by placing one or both hands in the point of operation, and a two hand control, presence sensing device of Type B gate or movable barrier (on a part revolution clutch) is used for safeguarding:
- (i) The employer shall use a control system and a brake monitor which comply with paragraphs (b)(13) and (14) of this section;
  - (ii) The exception in paragraph (b) (7)(v)(d) of this section for two hand controls manufactured and installed before August 31, 1971 is not applicable under this paragraph (c)(5);
  - (iii) The control of air clutch machines shall be designed to prevent a significant increase in the normal stopping time due to a failure within the operating valve mechanism, and to inhibit further operation if such failure does occur, where a part revolution clutch is employed. The exception in paragraph (b)(7)(xi) of this section for controls manufactured and installed before August 31, 1971, is not applicable under this paragraph (c)(5).
- (d) Design, construction, setting and feeding of dies.
- (1) General requirements. The employer shall: (i) Use dies and operating methods designed to control or eliminate hazards to operating personnel; and (ii) furnish and enforce the use of hand tools for freeing and removing stuck work or scrap pieces from the die, so that no employee need reach into the point of operation for such purposes.
  - (2) [Reserved]
  - (3) Scrap handling. The employer shall provide means for handling scrap from roll feed or random length stock operations. Scrap cutters used in conjunction with scrap handling systems shall be safeguarded in accordance with paragraph (c) of this section and with §1910.219.
  - (4) Guide post hazard. The hazard created by a guide post (when it is located in the immediate vicinity of the operator) when separated from its bushing by more than one-fourth inch shall be considered as a point of operation hazard and be protected in accordance with paragraph (c) of this section.

- (5) Unitized tooling. If unitized tooling is used, the opening between the top of the punch holder and the face of the slide, or striking pad, shall be safeguarded in accordance with the requirements of paragraph (c) of this section.
- (6) Tonnage, stroke, and weight designation. All dies shall be:
  - (i) Stamped with the tonnage and stroke requirements, or have these characteristics recorded if these records are readily available to the die setter;
  - (ii) Stamped to indicate upper die weight when necessary for air counterbalance pressure adjustment; and
  - (iii) Stamped to indicate complete die weight when handling equipment may become overloaded.
- (7) Die fastening. Provision shall be made in both the upper and lower shoes for securely mounting the die to the bolster and slide. Where clamp caps or setscrews are used in conjunction with punch stems, additional means of securing the upper shoe to the slide shall be used.
- (8) Die handling. Handling equipment attach points shall be provided on all dies requiring mechanical handling.
- (9) Diesetting.
  - (i) The employer shall establish a diesetting procedure that will insure compliance with paragraph (c) of this section.
  - (ii) The employer shall provide spring loaded turnover bars, for presses designed to accept such turnover bars.
  - (iii) The employer shall provide die stops or other means to prevent losing control of the die while setting or removing dies in presses which are inclined.
  - (iv) The employer shall provide and enforce the use of safety blocks for use whenever dies are being adjusted or repaired in the press.
  - (v) The employer shall provide brushes, swabs, lubricating rolls, and automatic or manual pressure guns so that operators and diesetters shall not be required to reach into the point of operation or other hazard areas to lubricate material, punches or dies.
- (e) Inspection, maintenance, and modification of presses.
  - (1) Inspection and maintenance records.
    - (i) It shall be the responsibility of the employer to establish and follow a program of periodic and regular inspections of his power presses to ensure that all their parts, auxiliary equipment, and safeguards are in a safe operating condition and adjustment. The employer shall maintain a certification record of inspections which includes the date of inspection, the signature of the person who performed the inspection and the serial number, or other identifier, of the power press that was inspected.
    - (ii) Each press shall be inspected and tested no less than weekly to determine the condition of the clutch/brake mechanism, antirepeat feature and single stroke mechanism. Necessary maintenance or repair or both shall be performed and completed before the press is operated. These requirements do not apply to those presses which comply with paragraphs (b) (13) and (14) of this section. The employer shall maintain a certification record of inspections, tests and maintenance work which includes the date of the inspection, test or maintenance; the signature of the person who performed the inspection, test, or maintenance; and the serial number or other identifier of the press that was inspected, tested or maintained.
  - (2) Modification. It shall be the responsibility of any person modifying a power press to furnish instructions with the modification to establish new or changed guidelines for use and care of the power press so modified.
  - (3) Training of maintenance personnel. It shall be the responsibility of the employer to insure the original and continuing competence of personnel caring for, inspecting, and maintaining power presses.

- (f) Operation of power presses.
- (1) [Reserved]
  - (2) Instruction to operators. The employer shall train and instruct the operator in the safe method of work before starting work on any operation covered by this section. The employer shall insure by adequate supervision that correct operating procedures are being followed.
  - (3) Work area. The employer shall provide clearance between machines so that movement of one operator will not interfere with the work of another. Ample room for cleaning machines, handling material, work pieces, and scrap shall also be provided. All surrounding floors shall be kept in good condition and free from obstructions, grease, oil, and water.
  - (4) Overloading. The employer shall operate his presses within the tonnage and attachment weight ratings specified by the manufacturer.

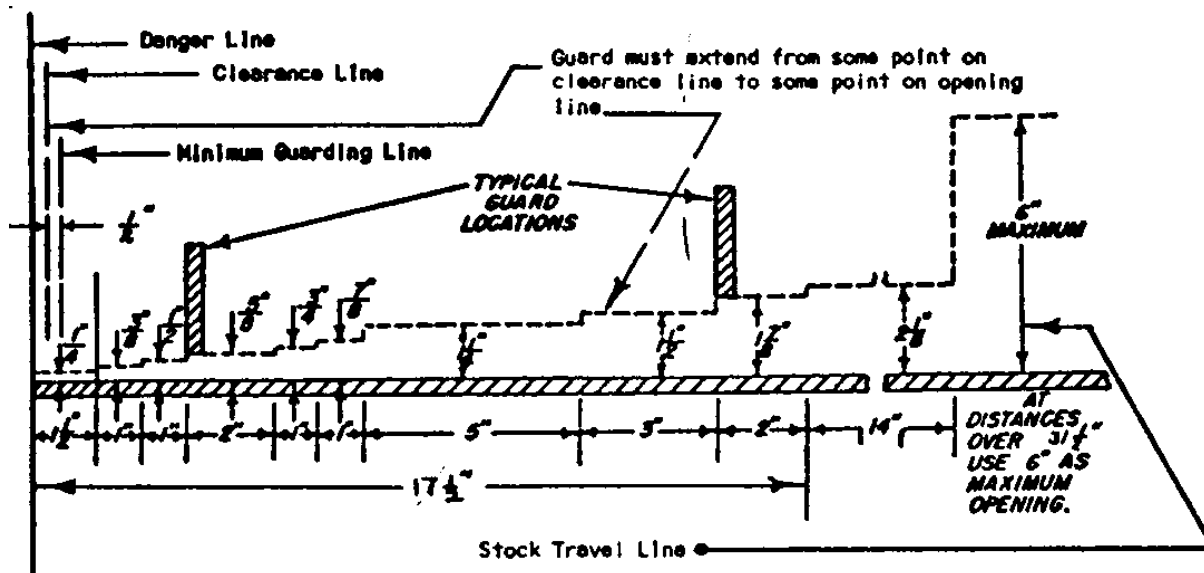

Explanation of above diagram:

This diagram shows the accepted safe openings between the bottom edge of a guard and feed table at various distances from the danger line (point of operation).

The clearance line marks the distance required to prevent contact between guard and moving parts.

The minimum guarding line is the distance between the infeed side of the guard and the danger line which is one-half inch from the danger line.

The various openings are such that for average size hands an operator's fingers won't reach the point of operation.

After installation of point of operation guards and before a job is released for operation a check should be made to verify that the guard will prevent the operator's hands from reaching the point of operation.

TABLE O-10  
[In inches]

| Distance of opening from point of operation hazard | Maximum width of opening |
|----------------------------------------------------|--------------------------|
| 2 to 12.....                                       | 3                        |
| 12 to 22.....                                      | d                        |
| 22 to 32.....                                      | 2                        |
| 32 to 52.....                                      | e                        |
| 52 to 62.....                                      | :                        |
| 62 to 72.....                                      | f                        |
| 72 to 122.....                                     | 13                       |
| 122 to 152.....                                    | 12                       |
| 152 to 172.....                                    | 1f                       |
| 172 to 312.....                                    | 2c                       |

This table shows the distances that guards shall be positioned from the danger line in accordance with the required openings.

- (g) Reports of injuries to employees operating mechanical power presses.**
  - (1) The employer shall, within 30 days of the occurrence, report to either the Director of the Directorate of Safety Standards Programs, OSHA, U.S. Department of Labor, Washington, D.C. 20210, or the State agency administering a plan approved by the Assistant Secretary of Labor for Occupational Safety and Health, all point of operation injuries to operators or other employees. The following information shall be included in the report:
    - (i) Employer's name, address and location of the workplace (establishment).
    - (ii) Employee's name, injury sustained, and the task being performed (operation, set-up, maintenance, or other).
    - (iii) Type of clutch used on the press (full revolution, part revolution, or direct drive).
    - (iv) Type of safeguard(s) being used (two hand control, two hand trip, pull-outs, sweeps, or other). If the safeguard is not described in this section, give a complete description.
    - (v) Cause of the accident (repeat of press, safeguard failure, removing stuck part or scrap, no safeguard provided, no safeguard in use, or other).
    - (vi) Type of feeding (manual with hands in dies or with hands out of dies, semiautomatic, automatic, or other).
    - (vii) Means used to actuate press stroke (foot trip, foot control, hand trip, hand control, or other).
    - (viii) Number of operators required for the operation and the number of operators provided with controls and safeguards.
- (h) Presence sensing device initiation (PSDI).**
  - (1) General.
    - (i) The requirements of paragraph (h) shall apply to all part revolution mechanical power presses used in the PSDI mode of operation.
    - (ii) The relevant requirements of paragraphs (a) through (g) of this section also shall apply to all presses used in the PSDI mode of operation whether or not cross referenced in this paragraph (h). Such cross-referencing of specific requirements from paragraphs (a) through (g) of this section is intended only to enhance convenience and understanding in relating to the new provisions to the existing standard, and is not to be construed as limiting the applicability of other provisions in paragraphs (a) through (g) of this section.
    - (iii) Full revolution mechanical power presses shall not be used in the PSDI mode of operation.
    - (iv) Mechanical power presses with a configuration which would allow a person to enter, pass through, and become clear of the sensing field into the hazardous portion of the press shall not be used in the PSDI mode of operation.

- (v) The PSDI mode of operation shall be used only for normal production operations. Die-setting and maintenance procedures shall comply with paragraphs (a) through (g) of this section, and shall not be done in the PSDI mode.
- (2) Brake and clutch requirements.
  - (i) Presses with flexible steel band brakes or with mechanical linkage actuated brakes or clutches shall not be used in the PSDI mode.
  - (ii) Brake systems on presses used in the PSDI mode shall have sufficient torque so that each average value of stopping times (Ts) for stops initiated at approximately 45 degrees, 60 degrees, and 90 degrees, respectively, of crankshaft angular position, shall not be more than 125 percent of the average value of the stopping time at the top crankshaft position. Compliance with this requirement shall be determined by using the heaviest upper die to be used on the press, and operating at the fastest press speed if there is speed selection.
  - (iii) Where brake engagement and clutch release is effected by spring action, such springs(s) shall operate in compression on a rod or within a hole or tube, and shall be of non-interleaving design.
- (3) Pneumatic systems.
  - (i) Air valve and air pressure supply/control.
    - (A) The requirements of paragraphs (b)(7)(xiii), (b)(7)(xiv), (b)(10), (b)(12) and (c)(5)(iii) of this section apply to the pneumatic systems of machines used in the PSDI mode.
    - (B) The air supply for pneumatic clutch/brake control valves shall incorporate a filter, an air regulator, and, when necessary for proper operation, a lubricator.
    - (C) The air pressure supply for clutch/brake valves on machines used in the PSDI mode shall be regulated to pressures less than or equal to the air pressure used when making the stop time measurements required by paragraph (h)(2)(ii) of this section.
  - (ii) Air counterbalance systems.
    - (A) Where presses that have slide counterbalance systems are used in the PSDI mode, the counterbalance system shall also meet the requirements of paragraph (b)(9) of this section.
    - (B) Counterbalances shall be adjusted in accordance with the press manufacturer's recommendations to assure correct counterbalancing of the slide attachment (upper die) weight for all operations performed on presses used in the PSDI mode. The adjustments shall be made before performing the stopping time measurements required by paragraphs (h)(2)(ii), (h)(5)(iii), and (h)(9)(v) of this section.
- (4) Flywheels and bearings. Presses whose designs incorporate flywheels running on journals on the crankshaft or back shaft, or bull gears running on journals mounted on the crankshaft, shall be inspected, lubricated, and maintained as provided in paragraph (h)(10) of this section to reduce the possibility of unintended and uncontrolled press strokes caused by bearing seizure.
- (5) Brake monitoring.
  - (i) Presses operated in the PSDI mode shall be equipped with a brake monitor that meets the requirements of paragraphs (b)(13) and (b)(14) of this section. In addition, the brake monitor shall be adjusted during installation certification to prevent successive stroking of the press if increases in stopping time cause an increase in the safety distance above that required by paragraph (h)(9)(v) of this section.
  - (ii) Once the PSDI safety system has been certified/validated, adjustment of the brake monitor shall not be done without prior approval of the validation organization for both the brake monitor adjustment and the corresponding adjustment of the safety distance. The validation organization shall in its installation validation, state that in what circumstances, if any, the employer has advance approval for adjustment, when prior oral approval is appropriate and when prior approval must be in writing. The adjustment shall be done under the supervision of an authorized person whose qualifications include knowledge of safety distance requirements and experience with the brake system and its adjustment. When brake wear or other factors extend press stopping time beyond the limit permitted by the brake monitor, adjustment, repair, or maintenance shall be performed on the brake or other press system element that extends the stopping time.

- (iii) The brake monitor setting shall allow an increase of no more than 10 percent of the longest stopping time for the press, or 10 milliseconds, whichever is longer, measured at the top of the stroke.
- (6) Cycle control and control systems.
  - (i) The control system on presses used in the PSDI mode shall meet the applicable requirements of paragraphs (b)(7), (b)(8), (b)(13), and (c)(5) of this section.
  - (ii) The control system shall incorporate a means of dynamically monitoring for decoupling of the rotary position indicating mechanism drive from the crankshaft. This monitor shall stop slide motion and prevent successive press strokes if decoupling occurs, or if the monitor itself fails.
  - (iii) The mode selection means of paragraph (b)(7)(iii) of this section shall have at least one position for selection of the PSDI mode. Where more than one interruption of the light sensing field is used in the initiation of a stroke, either the mode selection means must have one position for each function, or a separate selection means shall be provided which becomes operable when the PSDI mode is selected. Selection of PSDI mode and the number of interruptions/withdrawals of the light sensing field required to initiate a press cycle shall be by means capable of supervision by the employer.
  - (iv) A PSDI set-up/reset means shall be provided which requires an overt action by the operator, in addition to PSDI mode selection, before operation of the press by means of PSDI can be started.
  - (v) An indicator visible to the operator and readily seen by the employer shall be provided which shall clearly indicate that the system is set-up for cycling in the PSDI mode.
  - (vi) The control system shall incorporate a timer to deactivate PSDI when the press does not stroke within the period of time set by the timer. The timer shall be manually adjustable, to a maximum time of 30 seconds. For any timer setting greater than 15 seconds, the adjustment shall be made by the use of a special tool available only to authorized persons. Following a deactivation of PSDI by the timer, the system shall make it necessary to reset the set-up/reset means in order to reactivate the PSDI mode.
  - (vii) Reactivation of PSDI operation following deactivation of the PSDI mode from any other cause, such as activation of the red color stop control required by paragraph (b)(7)(ii) of this section, interruption of the presence sensing field, opening of an interlock, or reselection of the number of sensing field interruptions/withdrawals required to cycle the press, shall require resetting of the set-up/reset means.
  - (viii) The control system shall incorporate an automatic means to prevent initiation or continued operation in the PSDI mode unless the press drive motor is energized in the forward direction of crankshaft rotation.
  - (ix) The control design shall preclude any movement of the slide caused by operation of power on, power off, or selector switches, or from checks for proper operations as required by paragraph (h)(6)(xiv) of this section.
  - (x) All components and subsystems of the control system shall be designed to operate together to provide total control system compliance with the requirements of this section.
  - (xi) Where there is more than one operator of a press used for PSDI, each operator shall be protected by a separate, independently functioning, presence sensing device. The control system shall require that each sensing field be interrupted the selected number of times prior to initiating a stroke. Further, each operator shall be provided with a set-up/reset means that meets the requirements of paragraph (h)(6) of this section, and which must be actuated to initiate operation of the press in the PSDI mode.
  - (xii) [Reserved]
  - (xiii) The Control system shall incorporate interlocks for supplemental guards, if used, which will prevent stroke initiation or will stop a stroke in progress if any supplemental guard fails or is deactivated.
  - (xiv) The control system shall perform checks for proper operation of all cycle control logic element switches and contacts at least once each cycle. Control elements shall be checked for correct status after power "on" and before the initial PSDI stroke.

- (xv) The control system shall have provisions for an "inch" operating means meeting the requirements of paragraph (b)(7)(iv) of this section. Die-setting shall not be done the PSDI mode. Production shall not be done in the "inch" mode.
  - (xvi) The control system shall permit only a single stroke per initiation command.
  - (xvii) Controls with internally stored programs (e.g., mechanical, electro-mechanical, or electronic) shall meet the requirements of paragraph (b)(13) of this section, and shall default to a predetermined safe condition in the event of any single failure within the system. Programmable controllers which meet the requirements for controls with internally stored programs stated above shall be permitted only if all logic elements affecting the safety system and point of operation safety are internally stored and protected in such a manner that they cannot be altered or manipulated by the user to an unsafe condition.
- (7) Environmental requirements. Control components shall be selected, constructed, and connected together in such a way as to withstand expected operational and environmental stresses, at least including those outlined in appendix A. Such stresses shall not so affect the control system as to cause unsafe operation.
- (8) Safety system.
- (i) Mechanical power presses used in the PSDI mode shall be operated under the control of a safety system which, in addition to meeting the applicable requirements of paragraphs (b)(13) and (c)(5) and other applicable provisions of this section, shall function such that a single failure or single operating error shall not cause injury to personnel from point of operation hazards.
  - (ii) The safety system shall be designed, constructed, and arranged as an integral total system, including all elements of the press, the controls, the safeguarding and any required supplemental safeguarding, and their interfaces with the operator and that part of the environment which has effect on the protection against point of operation hazards.
- (9) Safeguarding the point of operation.
- (i) The point of operation of presses operated in the PSDI mode shall be safeguarded in accordance with the requirements of paragraph (c) of this section, except that the safety distance requirements of paragraph (h)(9)(v) of this section shall be used for PSDI operation.
  - (ii) (A) PSDI shall be implemented only by use of light curtain (photo-electric) presence sensing devices which meet the requirements of paragraph (c)(3)(iii)(c) of this section unless the requirements of the following paragraph have been met.  
(B) Alternatives to photo-electric light curtains may be used for PSDI when the employer can demonstrate, through tests and analysis by the employer or the manufacturer, that the alternative is as safe as the photo-electric light curtain, that the alternative meets the conditions of this section, has the same long term reliability as light curtains and can be integrated into the entire safety system as provided for in this section. Prior to use, both the employer and manufacturer must certify that these requirements and all the other applicable requirements of this section are met and these certifications must be validated by an OSHA-recognized third-party validation organization to meet these additional requirements and all the other applicable requirements of paragraphs (a) through (h) and appendix A of this section. Three months prior to the operation of any alternative system, the employer must notify the OSHA Directorate of Safety Standards programs of the name of the system to be installed, the manufacturer and the OSHA-recognized third-party validation organization immediately. Upon request, the employer must make available to that office all tests and analyses for OSHA review.
  - (iii) Individual sensing fields of presence sensing devices used to initiate strokes in the PSDI mode shall cover only one side of the press.
  - (iv) Light curtains used for PSDI operation shall have minimum object sensitivity not to exceed one and one-fourth inches (31.75 mm). Where light curtain object sensitivity is user-adjustable, either discretely or continuously, design features shall limit the minimum object sensitivity adjustment not to exceed one and one-fourth inches (31.75 mm). Blanking of the sensing field is not permitted.

- (v) The safety distance (Ds) from the sensing field of the presence sensing device to the point of operation shall be greater than or equal to the distance determined by the formula:

$$D_s = H_s \times (T_s + T_p + T_r + 2T_m) + D_p$$

Where:

Ds = Minimum safety distance.

Hs = Hand speed constant of 63 inches per second (1.6 m/s).

Ts = Longest press stopping time, in seconds, computed by taking averages of multiple measurements at each of three positions (45 degrees, 60 degrees, and 90 degrees) of crankshaft angular position; the longest of the three averages is the stopping time to use. (Ts is defined as the sum of the kinetic energy dissipation time plus the pneumatic/magnetic/hydraulic reaction time of the clutch/brake operating mechanism(s).)

Tp = Longest presence sensing device response time, in seconds.

Tr = Longest response time, in seconds, of all interposing control elements between the presence sensing device and the clutch/brake operating mechanism(s).

Tm = Increase in the press stopping time at the top of the stroke, in seconds, allowed by the brake monitor for brake wear. The time increase allowed shall be limited to no more than 10 percent of the longest press stopping time measured at the top of the stroke, or 10 milliseconds, whichever is longer.

Dp = Penetration depth factor, required to provide for possible penetration through the presence sensing field by fingers or hand before detection occurs. The penetration depth factor shall be determined from Graph h-1 using the minimum object sensitivity size.

- (vi) The presence sensing device location shall either be set at each tool change and set-up to provide at least the minimum safety distance, or fixed in location to provide a safety distance greater than or equal to the minimum safety distance for all tooling set-ups which are to be used on that press.
- (vii) Where presence sensing device location is adjustable, adjustment shall require the use of a special tool available only to authorized persons.
- (viii) Supplemental safeguarding shall be used to protect all areas of access to the point of operation which are unprotected by the PSDI presence sensing device. Such supplemental safeguarding shall consist of either additional light curtain (photo-electric) presence sensing devices or other types of guards which meet the requirements of paragraphs (c) and (h) of this section.
  - (A) Presence sensing devices used as supplemental safeguarding shall not initiate a press stroke, and shall conform to the requirements of paragraph (c)(3)(iii) and other applicable provisions of this section, except that the safety distance shall comply with paragraph (h)(9)(v) of this section.
  - (B) Guards used as supplemental safeguarding shall conform to the design, construction and application requirements of paragraph (c)(2) of this section, and shall be interlocked with the press control to prevent press PSDI operation if the guard fails, is removed, or is out of position.
- (ix) Barriers shall be fixed to the press frame or bolster to prevent personnel from passing completely through the sensing field, where safety distance or press configuration is such that personnel could pass through the PSDI presence sensing field and assume a position where the point of operation could be accessed without detection by the PSDI presence sensing device. As an alternative, supplemental presence sensing devices used only in the safeguard mode may be provided. If used, these devices shall be located so as to detect all operator locations and positions not detected by the PSDI sensing field, and shall prevent stroking or stop a stroke in process when any supplemental sensing field(s) are interrupted.
- (x) Hand tools. Where tools are used for feeding, removal of scrap, lubrication of parts, or removal of parts that stick on the die in PSDI operations:
  - (A) The minimum diameter of the tool handle extension shall be greater than the minimum object sensitivity of the presence sensing device(s) used to initiate press strokes; or

- (B) The length of the hand tool shall be such as to ensure that the operator's hand will be detected for any safety distance required by the press set-ups.
- (10) Inspection and maintenance.
- (i) Any press equipped with presence sensing devices for use in PSDI, or for supplemental safeguarding on presses used in the PSDI mode, shall be equipped with a test rod of diameter specified by the presence sensing device manufacturer to represent the minimum object sensitivity of the sensing field. Instructions for use of the test rod shall be noted on a label affixed to the presence sensing device.
  - (ii) The following checks shall be made at the beginning of each shift and whenever a die change is made.
    - (A) A check shall be performed using the test rod according to the presence sensing device manufacturer's instructions to determine that the presence sensing device used for PSDI is operational.
    - (B) The safety distance shall be checked for compliance with (h)(9)(v) of this section.
    - (C) A check shall be made to determine that all supplemental safeguarding is in place. Where presence sensing devices are used for supplemental safeguarding, a check for proper operation shall be performed using the test rod according to the presence sensing device manufacturer's instructions.
    - (D) A check shall be made to assure that the barriers and/or supplemental presence sensing devices required by paragraph (h)(9)(ix) of this section are operating properly.
    - (E) A system or visual check shall be made to verify correct counterbalance adjustment for die weight according to the press manufacturer's instructions, when a press is equipped with a slide counterbalance system.
  - (iii) When presses used in the PSDI mode have flywheel or bullgear running on crankshaft mounted journals and bearings, or a flywheel mounted on back shaft journals and bearings, periodic inspections following the press manufacturer's recommendations shall be made to ascertain that bearings are in good working order, and that automatic lubrication systems for these bearings (if automatic lubrication is provided) are supplying proper lubrication. On presses with provision for manual lubrication of flywheel or bullgear bearings, lubrication shall be provided according to the press manufacturer's recommendations.
  - (iv) Periodic inspections of clutch and brake mechanisms shall be performed to assure they are in proper operating condition. The press manufacturer's recommendations shall be followed.
  - (v) When any check of the press, including those performed in accordance with the requirements of paragraphs (h)(10)(ii), (iii) or (iv) of this section, reveals a condition of noncompliance, improper adjustment, or failure, the press shall not be operated until the condition has been corrected by adjustment, replacement, or repair.
  - (vi) It shall be the responsibility of the employer to ensure the competence of personnel caring for, inspecting, and maintaining power presses equipped for PSDI operation, through initial and periodic training.
- (11) Safety system certification/validation.
- (i) Prior to the initial use of any mechanical press in the PSDI mode, two sets of certification and validation are required:
    - (A) The design of the safety system required for the use of a press in the PSDI mode shall be certified and validated prior to installation. The manufacturer's certification shall be validated by an OSHA-recognized third-party validation organization to meet all applicable requirements of paragraphs (a) through (h) and appendix A of this section.
    - (B) After a press has been equipped with a safety system whose design has been certified and validated in accordance with paragraph (h)(11)(i) of this section, the safety system installation shall be certified by the employer, and then shall be validated by an OSHA-recognized third-party validation organization to meet all applicable requirements of paragraphs (a) through (h) and appendix A of this section.
  - (ii) At least annually thereafter, the safety system on a mechanical power press used in the PSDI mode shall be recertified by the employer and revalidated by an OSHA-recognized third-party validation organization to meet all applicable requirements of paragraphs (a) through (h) and appendix A of this section. Any press whose safety system has not been

- recertified and revalidated within the preceding 12 months shall be removed from service in the PSDI mode until the safety system is recertified and revalidated.
- (iii) A label shall be affixed to the press as part of each installation certification/validation and the most recent recertification/revalidation. The label shall indicate the press serial number, the minimum safety distance (Ds) required by paragraph (h)(9)(v) of this section, the fulfillment of design recertification/validation, the employer's signed certification, the identification of the OSHA-recognized third-party validation organization, its signed validation, and the date the certification/validation and recertification/revalidation are issued.
  - (iv) Records of the installation certification and validation and the most recent recertification and revalidation shall be maintained for each safety system equipped press by the employer as long as the press is in use. The records shall include the manufacture and model number of each component and subsystem, the calculations of the safety distance as required by paragraph (h)(9)(v) of this section, and the stopping time measurements required by paragraph (h)(2)(ii) of this section. The most recent records shall be made available to OSHA upon request.
  - (v) The employer shall notify the OSHA-recognized third-party validation organization within five days whenever a component or a subsystem of the safety system fails or modifications are made which may affect the safety of the system. The failure of a critical component shall necessitate the removal of the safety system from service until it is recertified and revalidated, except recertification by the employer without revalidation is permitted when a non-critical component or subsystem is replaced by one of the same manufacture and design as the original, or determined by the third-party validation organization to be equivalent by similarity analysis, as set forth in appendix A.
  - (vi) The employer shall notify the OSHA-recognized third-party validation organization within five days of the occurrence of any point of operation injury while a press is used in the PSDI mode. This is in addition to the report of injury required by paragraph (g) of this section; however, a copy of that report may be used for this purpose.
- (12) Die setting and work set-up.
- (i) Die setting on presses used in the PSDI mode shall be performed in accordance with paragraphs (d) and (h) of this section.
  - (ii) The PSDI mode shall not be used for die setting or set-up. An alternative manual cycle initiation and control means shall be supplied for use in die setting which meets the requirements of paragraph (b)(7) of this section.
  - (iii) Following a die change, the safety distance, the proper application of supplemental safeguarding, and the slide counterbalance adjustment (if the press is equipped with a counterbalance) shall be checked and maintained by authorized persons whose qualifications include knowledge of the safety distance, supplemental safe-guarding requirements, and the manufacturer's specifications for counterbalance adjustment. Adjustment of the location of the PSDI presence sensing device shall require use of a special tool available only to the authorized persons.
- (13) Operator training.
- (i) The operator training required by paragraph (f)(2) of this section shall be provided to the employee before the employee initially operates the press and as needed to maintain competence, but not less than annually thereafter. It shall include instruction relative to the following items for presses used in the PSDI mode.
    - (A) The manufacturer's recommended test procedures for checking operation of the presence sensing device. This shall include the use of the test rod required by paragraph (h)(10)(i) of this section.
    - (B) The safety distance required.
    - (C) The operation, function and performance of the PSDI mode.
    - (D) The requirements for hand tools that may be used in the PSDI mode.
    - (E) The severe consequences that can result if he or she attempts to circumvent or by-pass any of the safe-guard or operating functions of the PSDI system.
  - (ii) The employer shall certify that employees have been trained by preparing a certification record which includes the identity of the person trained, the signature of the employer or the person who conducted the training, and the date the training was completed. The

certification record shall be prepared at the completion of training and shall be maintained on file for the duration of the employee's employment. The certification record shall be made available upon request to the Assistant Secretary for Occupational Safety and Health.

**APPENDIX A TO §1910.217--MANDATORY REQUIREMENTS FOR  
CERTIFICATION/VALIDATION OF SAFETY SYSTEMS FOR PRESENCE SENSING DEVICE  
INITIATION OF MECHANICAL POWER PRESSES**

Purpose

The purpose of the certification/validation of safety systems for presence sensing device initiation (PSDI) of mechanical power presses is to ensure that the safety systems are designed, installed, and maintained in accordance with all applicable requirements of 29 CFR 1910.217 (a) through (h) and this appendix A.

General

The certification/validation process shall utilize an independent third-party validation organization recognized by OSHA in accordance with the requirements specified in appendix C of this section.

While the employer is responsible for assuring that the certification/validation requirements in §1910.217(h)(11) are fulfilled, the design certification of PSDI safety systems may be initiated by manufacturers, employers, and/or their representatives. The term "manufacturers" refers to the manufacturer of any of the components of the safety system. An employer who assembles a PSDI safety system would be a manufacturer as well as employer for purposes of this standard and Appendix.

The certification/validation process includes two stages. For design certification, in the first stage, the manufacturer (which can be an employer) certifies that the PSDI safety system meets the requirements of 29 CFR 1910.217 (a) through (h) and this appendix A, based on appropriate design criteria and tests. In the second stage, the OSHA-recognized third-party validation organization validates that the PSDI safety system meets the requirements of 29 CFR 1910.217 (a) through (h) and this appendix A and the manufacturer's certification by reviewing the manufacturer's design and test data and performing any additional reviews required by this standard or which it believes appropriate.

For installation certification/validation and annual recertification/revalidation, in the first stage the employer certifies or recertifies that the employer is installing or utilizing a PSDI safety system validated as meeting the design requirements of 29 CFR 1910.217 (a) through (h) and this appendix A by an OSHA-recognized third-party validation organization and that the installation, operation and maintenance meet the requirements of 29 CFR 1910.217 (a) through (h) and this appendix A. In the second stage, the OSHA-recognized third-party validation organization validates or revalidates that the PSDI safety system installation meets the requirements of 29 CFR 1910.217 (a) through (h) and this appendix A and the employer's certification, by reviewing that the PSDI safety system has been certified; the employer's certification, designs and tests, if any; the installation, operation, maintenance and training; and by performing any additional tests and reviews which the validation organization believes is necessary.

Summary

The certification/validation of safety systems for PSDI shall consider the press, controls, safeguards, operator, and environment as an integrated system which shall comply with all of the requirements in 29 CFR 1910.217 (a) through (h) and this appendix A. The certification/validation process shall verify that the safety system complies with the OSHA safety requirements as follows:

A. Design Certification/Validation

1. The major parts, components and subsystems used shall be defined by part number or serial number, as appropriate, and by manufacturer to establish the configuration of the system.
2. The identified parts, components and subsystems shall be certified by the manufacturer to be able to withstand the functional and operational environments of the PSDI safety system.

3. The total system design shall be certified by the manufacturer as complying with all requirements in 29 CFR 1910.217 (a) through (h) and this appendix A.

4. The third-party validation organization shall validate the manufacturer's certification under paragraphs 2 and 3.

#### B. Installation Certification/Validation

1. The employer shall certify that the PSDI safety system has been design certified and validated, that the installation meets the operational and environmental requirements specified by the manufacturer, that the installation drawings are accurate, and that the installation meets the requirements of 29 CFR 1910.217 (a) through (h) and this appendix A. (The operational and installation requirements of the PSDI safety system may vary for different applications.)

2. The third-party validation organization shall validate the employer's certifications that the PSDI safety system is design certified and validated, that the installation meets the installation and environmental requirements specified by the manufacturer, and that the installation meets the requirements of 29 CFR 1910.217 (a) through (h) and this appendix A.

#### C. Recertification/Revalidation

1. The PSDI safety system shall remain under certification/validation for the shorter of one year or until the system hardware is changed, modified or refurbished, or operating conditions are changed (including environmental, application or facility changes), or a failure of a critical component has occurred.

2. Annually, or after a change specified in paragraph 1., the employer shall inspect and recertify the installation as meeting the requirements set forth under B., Installation Certification/Validation.

3. The third-party validation organization, annually or after a change specified in paragraph 1., shall validate the employer's certification that the requirements of paragraph B., Installation Certification/Validation have been met.

(NOTE: Such changes in operational conditions as die changes or press relocations not involving disassembly or revision to the safety system would not require recertification/revalidation.)

#### Certification/Validation Requirements

##### A. General Design Certification/Validation Requirements

1. Certification/Validation Program Requirements. The manufacturer shall certify and the OSHA-recognized third-party validation organization shall validate that:

- a. The design of components, subsystems, software and assemblies meets OSHA performance requirements and are ready for the intended use; and
- b. The performance of combined subsystems meets OSHA's operational requirements.

2. Certification/Validation Program Level of Risk Evaluation Requirements. The manufacturer shall evaluate and certify, and the OSHA-recognized third-party validation organization shall validate, the design and operation of the safety system by determining conformance with the following:

- a. The safety system shall have the ability to sustain a single failure or a single operating error and not cause injury to personnel from point of operation hazards. Acceptable design features shall demonstrate, in the following order or precedence, that:
  - (1) No single failure points may cause injury; or
  - (2) Redundancy, and comparison and/or diagnostic checking, exist for the critical items that may cause injury, and the electrical, electronic, electromechanical and mechanical parts and components are selected so that they can withstand operational and external environments. The safety factor and/or derated percentage shall be specifically noted and complied with.

- b. The manufacturer shall design, evaluate, test and certify, and the third-party validation organization shall evaluate and validate, that the PSDI safety system meets appropriate requirements in the following areas.

(1) Environmental Limits:

- (a) Temperature

- (b) Relative humidity
- (c) Vibration
- (d) Fluid compatibility with other materials
- (2) Design Limits
  - (a) Power requirements
  - (b) Power transient tolerances
  - (c) Compatibility of materials used
  - (d) Material stress tolerances and limits
  - (e) Stability to long term power fluctuations
  - (f) Sensitivity to signal acquisition
  - (g) Repeatability of measured parameter without inadvertent initiation of a press stroke
  - (h) Operational life of components in cycles, hours, or both
  - (i) Electromagnetic tolerance to:
    - (1) Specific operational wave lengths; and
    - (2) Externally generated wave lengths
    - (3) New Design Certification/Validation. Design certification/validation for a new safety system, i.e., a new design or new integration of specifically identified components and subsystems, would entail a single certification/validation which would be applicable to all identical safety systems. It would not be necessary to repeat the tests on individual safety systems of the same manufacture or design. Nor would it be necessary to repeat these tests in the case of modifications where determined by the manufacturer and validated by the third-party validation organization to be equivalent by similarity analysis. Minor modifications not affecting the safety of the system may be made by the manufacturer without revalidation. Substantial modifications would require testing as a new safety system, as deemed necessary by the validation organization.

#### B. Additional Detailed Design Certification/Validation Requirements

1. General. The manufacturer or the manufacturer's representative shall certify to and submit to an OSHA-recognized third-party validation organization the documentation necessary to demonstrate that the PSDI safety system design is in full compliance with the requirements of 29 CFR 1910.217(a)-(h) and this appendix A, as applicable, by means of analysis, tests, or combination of both, establishing that the following additional certification/validation requirements are fulfilled.

2. Reaction Times. For the purpose of demonstrating compliance with the reaction time required by §1910.217(h), the tests shall use the following definitions and requirements:

- a. **Reaction time** means the time, in seconds, it takes the signal, required to activate/deactivate the system, to travel through the system, measured from the time of signal initiation to the time the function being measured is completed.
- b. **Full stop or No movement of the slide or ram** means when the crankshaft rotation has slowed to two or less revolutions per minute, just before stopping completely.
- c. **Function completion** means for, electrical, electromechanical and electronic devices, when the circuit produces a change of state in the output element of the device.
- d. When the change of state is motion, the measurement shall be made at the completion of the motion.
- e. The generation of the test signal introduced into the system for measuring reaction time shall be such that the initiation time can be established with an error of less than 0.5 percent of the reaction time measured.
- f. The instrument used to measure reaction time shall be calibrated to be accurate to within 0.001 second.

3. Compliance with §1910.21 7(h)(2)(ii). For compliance with these requirements, the average value of the stopping time,  $T_s$ , shall be the arithmetic mean of at least 25 stops for each stop angle initiation measured with the brake and/or clutch unused, 50 percent worn, and 90 percent worn. The recommendations of the brake system manufacturer shall be used to simulate or estimate the brake wear. The manufacturer's recommended minimum lining depth shall be identified and documented, and an

evaluation made that the minimum depth will not be exceeded before the next (annual) recertification/revalidation. A correlation of the brake and/or clutch degradation based on the above tests and/or estimates shall be made and documented. The results shall document the conditions under which the brake and/or clutch will and will not comply with the requirement. Based upon this determination, a scale shall be developed to indicate the allowable 10 percent of the stopping time at the top of the stroke for slide or ram overtravel due to brake wear. The scale shall be marked to indicate that brake adjustment and/or replacement is required. The explanation and use of the scale shall be documented.

The test specification and procedure shall be submitted to the validation organization for review and validation prior to the test. The validation organization representative shall witness at least one set of tests.

4. Compliance with §1910.217(h)(5)(iii) and (h)(9)(v). Each reaction time required to calculate the Safety Distance, including the brake monitor setting, shall be documented in separate reaction time tests. These tests shall specify the acceptable tolerance band sufficient to assure that tolerance build-up will not render the safety distance unsafe.

- a. Integrated test of the press fully equipped to operate in the PSDI mode shall be conducted to establish the total system reaction time.
  - b. Brakes which are the adjustable type shall be adjusted properly before the test.
5. Compliance with §1910.217(h)(2)(iii).
- a. Prior to conducting the brake system test required by paragraph (h)(2)(ii), a visual check shall be made of the springs. The visual check shall include a determination that the spring housing or rod does not show damage sufficient to degrade the structural integrity of the unit, and the spring does not show any tendency to interleave.
  - b. Any detected broken or unserviceable springs shall be replaced before the test is conducted. The test shall be considered successful if the stopping time remains within that which is determined by paragraph (h)(9)(v) for the safety distance setting. If the increase in press stopping time exceeds the brake monitor setting limit defined in paragraph (h)(5)(iii), the test shall be considered unsuccessful, and the cause of the excessive stopping time shall be investigated. It shall be ascertained that the springs have not been broken and that they are functioning properly.
6. Compliance with §1910.217(h)(7).
- a. Tests which are conducted by the manufacturers of electrical components to establish stress, life, temperature and loading limits must be tests which are in compliance with the provisions of the National Electrical Code.
  - b. Electrical and/or electronic cards or boards assembled with discreet components shall be considered a subsystem and shall require separate testing that the subsystems do not degrade in any of the following conditions:
    - (1) Ambient temperature variation from  $-20^{\circ}\text{C}$  to  $+50^{\circ}\text{C}$ .
    - (2) Ambient relative humidity of 99 percent.
    - (3) Vibration of 45G for one millisecond per stroke when the item is to be mounted on the press frame.
    - (4) Electromagnetic interference at the same wavelengths used for the radiation sensing field, at the power line frequency fundamental and harmonics, and also from outogenous radiation due to system switching.
    - (5) Electrical power supply variations of  $\square 15$  percent.
  - c. The manufacturer shall specify the test requirements and procedures from existing consensus tests in compliance with the provisions of the National Electrical Code.
  - d. Tests designed by the manufacturer shall be made available upon request to the validation organization. The validation organization representative shall witness at least one set of each of these tests.
7. Compliance with §1910.217(h)(9)(iv).
- a. The manufacturer shall design a test to demonstrate that the prescribed minimum object sensitivity of the presence sensing device is met.
  - b. The test specifications and procedures shall be made available upon request to the validation organization.
8. Compliance with §1910.217(h)(9)(x).
- a. The manufacturer shall design a test(s) to establish the hand tool extension diameters allowed for variations in minimum object sensitivity response.

- b. The test(s) shall document the range of object diameter sizes which will produce both single and double break conditions.
  - c. The test(s) specifications and procedures shall be made available upon request to the validation organization.
9. Integrated Tests Certification/Validation
- a. The manufacturer shall design a set of integrated tests to demonstrate compliance with the following requirements:  
Sections 1910.217(h)(6) (ii); (iii); (iv); (v); (vi); (vii); (viii); (ix); (xi); (xii); (xiii); (xiv); (xv); and (xvii).
  - b. The integrated test specifications and procedures shall be made available to the validation organization.
10. Analysis.
- a. The manufacturer shall submit to the validation organization the technical analysis such as Hazard Analysis, Failure Mode and Effect Analysis, Stress Analysis, Component and Material Selection Analysis, Fluid Compatibility, and/or other analyses which may be necessary to demonstrate, compliance with the following requirements:  
Sections 1910.217(h)(8) (i) and (ii); (h)(2)(ii) and (iii); (h)(3)(i) (A) and (C), and (ii); (h)(5) (i), (ii) and (iii); (h)(6) (i), (iii), (iv), (vi), (vii), (viii), (ix), (x), (xi), (xiii), (xiv), (xv), (xvi), and (xvii); (h)(7) (i) and (ii); (h)(9) (iv), (v), (viii), (ix) and (x); (h)(10) (i) and (ii).
11. Types of Tests Acceptable for Certification/Validation.
- a. Test results obtained from development testing may be used to certify/validate the design.
  - b. The test results shall provide the engineering data necessary to establish confidence that the hardware and software will meet specifications, the manufacturing process has adequate quality control and the data acquired was used to establish processes, procedures, and test levels supporting subsequent hardware design, production, installation and maintenance.
12. Validation for Design Certification/Validation. If, after review of all documentation, tests, analyses, manufacturer's certifications, and any additional tests which the third-party validation organization believes are necessary, the third-party validation organization determines that the PSDI safety system is in full compliance with the applicable requirements of 29 CFR 1910.217(a) through (h) and this appendix A, it shall validate the manufacturer's certification that it so meets the stated requirements.

### C. Installation Certification/Validation Requirements

1. The employer shall evaluate and test the PSDI system installation, shall submit to the OSHA-recognized third-party validation organization the necessary supporting documentation, and shall certify that the requirements of §1910.217(a) through (h) and this appendix A have been met and that the installation is proper.
2. The OSHA-recognized third-party validation organization shall conduct tests, and/or review and evaluate the employer's installation tests, documentation and representations. If it so determines, it shall validate the employer's certification that the PSDI safety system is in full conformance with all requirements of 29 CFR 1910.217(a) through (h) and this appendix A.

### D. Recertification/Revalidation Requirements

1. A PSDI safety system which has received installation certification/validation shall undergo recertification/revalidation the earlier of:
  - a. Each time the systems hardware is significantly changed, modified, or refurbished;
  - b. Each time the operational conditions are significantly changed (including environmental, application or facility changes, but excluding such changes as die changes or press relocations not involving revision to the safety system);
  - c. When a failure of a significant component has occurred or a change has been made which may affect safety; or

- d. When one year has elapsed since the installation certification/validation or the last recertification/revalidation.
2. Conduct or recertification/revalidation. The employer shall evaluate and test the PSDI safety system installation, shall submit to the OSHA-recognized third-party validation organization the necessary supporting documentation, and shall recertify that the requirements of §1910.217(a) through (h) and this appendix are being met. The documentation shall include, but not be limited to, the following items:
  - a. Demonstration of a thorough inspection of the entire press and PSDI safety system to ascertain that the installation, components and safeguarding have not been changed, modified or tampered with since the installation certification/validation or last recertification/revalidation was made.
  - b. Demonstrations that such adjustments as may be needed (such as to the brake monitor setting) have been accomplished with proper changes made in the records and on such notices as are located on the press and safety system.
  - c. Demonstration that review has been made of the reports covering the design certification/validation, the installation certification/validation, and all recertification/revalidations, in order to detect any degradation to an unsafe condition, and that necessary changes have been made to restore the safety system to previous certification/validation levels.
3. The OSHA-recognized third-party validation organization shall conduct tests, and/or review and evaluate the employer's installation, tests, documentation and representations. If it so determines, it shall revalidate the employer's recertification that the PSDI system is in full conformance with all requirements of 29 CFR 1910.217(a) through (h) and this appendix A.

**APPENDIX B TO §1910.217B NONMANDATORY GUIDELINES FOR CERTIFICATION/VALIDATION  
OF SAFETY SYSTEMS FOR PRESENCE SENSING DEVICE INITIATION  
OF MECHANICAL POWER PRESSES**

Objectives

This Appendix provides employers, manufacturers, and their representatives, with nonmandatory guidelines for use in developing certification documents. Employers and manufacturers are encouraged to recommend other approaches if there is a potential for improving safety and reducing cost. The guidelines apply to certification/validation activity from design evaluation through the completion of the installation test and the annual recertification/revalidation tests.

General Guidelines

A. The certification/validation process should confirm that hazards identified by hazard analysis, (HA), failure mode effect analysis (FMEA), and other system analyses have been eliminated by design or reduced to an acceptable level through the use of appropriate design features, safety devices, warning devices, or special procedures. The certification/validation process should also confirm that residual hazards identified by operational analysis are addressed by warning, labeling safety instructions or other appropriate means.

B. The objective of the certification/validation program is to demonstrate and document that the system satisfies specification and operational requirements for safe operations.

Quality Control

The safety attributes of a certified/validated PSDI safety system are more likely to be maintained if the quality of the system and its parts, components and subsystem is consistently controlled. Each manufacturer supplying parts, components, subsystems, and assemblies needs to maintain the quality of the product, and each employer needs to maintain the system in a non-degraded condition.

Analysis Guidelines

- A. Certification/validation of hardware design below the system level should be accomplished by test and/or analysis.
- B. Analytical methods may be used in lieu of, in combination with, or in support of tests to satisfy specification requirements.
- C. Analyses may be used for certification/validation when existing data are available or when test is not feasible.
- D. Similarity analysis may be used in lieu of tests where it can be shown that the article is similar in design, manufacturing process, and quality control to another article that was previously certified/validated in accordance with equivalent or more stringent criteria. If previous design, history and application are considered to be similar, but not equal to or more exacting than earlier experiences, the additional or partial certification/validation tests should concentrate on the areas of changed or increased requirements.

### Analysis Reports

The analysis reports should identify: (1) The basis for the analysis; (2) the hardware or software items analyzed; (3) conclusions; (4) safety factors; and (5) limit of the analysis. The assumptions made during the analysis should be clearly stated and a description of the effects of these assumptions on the conclusions and limits should be included.

Certification/validation by similarity analysis reports should identify, in addition to the above, application of the part, component or subsystem for which certification/validation is being sought as well as data from previous usage establishing adequacy of the item. Similarity analysis should not be accepted when the internal and external stresses on the item being certified/validated are not defined.

Usage experience should also include failure data supporting adequacy of the design.

### **APPENDIX C TO §1910.217--MANDATORY REQUIREMENTS FOR OSHA RECOGNITION OF THIRD-PARTY VALIDATION ORGANIZATIONS FOR THE PSDI STANDARD**

This Appendix prescribes mandatory requirements and procedures for OSHA recognition of third-party validation organizations to validate employer and manufacturer certifications that their equipment and practices meet the requirements of the PSDI standard. The scope of the Appendix includes the three categories of certification/validation required by the PSDI standard: Design Certification/Validation, Installation Certification/Validation, and Annual Recertification/Revalidation.

If further detailing of these provisions will assist the validation organization or OSHA in this activity, this detailing will be done through appropriate OSHA Program Directives.

#### I. Procedure for OSHA Recognition of Validation Organizations

##### A. Applications

1. Eligibility.
  - a. Any person or organization considering itself capable of conducting a PSDI-related third-party validation function may apply for OSHA recognition.
  - b. However, in determining eligibility for a foreign-based third-party validation organization, OSHA shall take into consideration whether there is reciprocity of treatment by the foreign government after consultation with relevant U.S. government agencies.
2. Content of application.
  - a. The application shall identify the scope of the validation activity for which the applicant wishes to be recognized, based on one of the following alternatives:
    - (1) Design Certification/Validation, Installation Certification/Validation, and Annual Recertification/Revalidation;
    - (2) Design Certification/Validation only; or
    - (3) Installation/Certification/Validation and Annual Recertification/Revalidation.
  - b. The application shall provide information demonstrating that it and any validating laboratory utilized meet the qualifications set forth in section II of this Appendix.
  - c. The applicant shall provide information demonstrating that it and any validating laboratory utilized meet the program requirements set forth in section III of this Appendix.

- d. The applicant shall identify the test methods it or the validating laboratory will use to test or judge the components and operations of the PSDI safety system required to be tested by the PSDI standard and Appendix A, and shall specify the reasons the test methods are appropriate.
  - e. The applicant may include whatever enclosures, attachments, or exhibits the applicant deems appropriate. The application need not be submitted on a Federal form.
  - f. The applicant shall certify that the information submitted is accurate.
3. Filing office location. The application shall be filed with: PSDI Certification/Validation Program, Office of Variance Determination, Occupational Safety and Health Administration, U.S. Department of Labor, Room N3653, 200 Constitution Avenue, NW., Washington, DC 20210.
  4. Amendments and withdrawals.
    - a. An application may be revised by an applicant at any time prior to the completion of the final staff recommendation.
    - b. An application may be withdrawn by an applicant, without prejudice, at any time prior to the final decision by the Assistant Secretary in paragraph I.B.8.b.(4) of this Appendix.

### B. Review and Decision Process

1. Acceptance and field inspection. All applications submitted will be accepted by OSHA, and their receipt acknowledged in writing. After receipt of an application, OSHA may request additional information if it believes information relevant to the requirements for recognition have been omitted. OSHA may inspect the facilities of the third-party validation organization and any validating laboratory, and while there shall review any additional documentation underlying the application. A report shall be made of each field inspection.
2. Requirements for recognition. The requirements for OSHA recognition of a third-party validation organization for the PSDI standard are that the program has fulfilled the requirements of section II of this Appendix for qualifications and of section III of this Appendix for program requirements, and the program has identified appropriate test and analysis methods to meet the requirements of the PSDI standard and Appendix A.
3. Preliminary approval. If, after review of the application, any additional information, and the inspection report, the applicant and any validating laboratory appear to have met the requirements for recognition, a written recommendation shall be submitted by the responsible OSHA personnel to the Assistant Secretary to approve the application with a supporting explanation.
4. Preliminary disapproval. If, after review of the application, additional information, and inspection report, the applicant does not appear to have met the requirements for recognition, the Director of the PSDI certification/validation program shall notify the applicant in writing, listing the specific requirements of this Appendix which the applicant has not met, and the reasons.
5. Revision of application. After receipt of a notification of preliminary disapproval the applicant may submit a revised application for further review by OSHA pursuant to subsection I.B. of this Appendix or any request that the original application be submitted to the Assistant Secretary with a statement of reasons supplied by the applicant as to why the application should be approved.
6. Preliminary decision by Assistant Secretary.
  - a. The Assistant Secretary, or a special designee for this purpose, will make a preliminary decision whether the applicant has met the requirements for recognition based on the completed application file and the written staff recommendation, as well as the statement of reasons by the applicant if there is a recommendation of disapproval.
  - b. This preliminary decision will be sent to the applicant and subsequently published in the FEDERAL REGISTER.
7. Public review and comment period.
  - a. The FEDERAL REGISTER notice of preliminary decision will provide a period of not less than 60 calendar days for the written comments on the applicant's fulfillment of the requirements for recognition. The application, supporting documents, staff recommendation, statement of applicant's reasons, and any comments received, will be available for public inspection in the OSHA Docket Office.
  - b. If the preliminary decision is in favor of recognition, a member of the public, or if the preliminary decision is against recognition, the applicant may request a public hearing by

the close of the comment period, if it supplies detailed reasons and evidence challenging the basis of the Assistant Secretary's preliminary decision and justifying the need for a public hearing to bring out evidence which could not be effectively supplied through written submissions.

8. Final decision by Assistant Secretary.
  - a. Without hearing. If there are no valid requests for a hearing, based on the application, supporting documents, staff recommendation, evidence and public comment, the Assistant Secretary shall issue the final decision (including reasons) of the Department of Labor on whether the applicant has demonstrated by a preponderance of the evidence that it meets the requirements for recognition.
  - b. After hearing. If there is a valid request for a hearing pursuant to paragraph I.B.7.b. of this Appendix, the following procedures will be used:
    - (1) The Assistant Secretary will issue a notice of hearing before an administrative law judge of the Department of Labor pursuant to the rules specified in 29 CFR Part 1905, Subpart C.
    - (2) After the hearing, pursuant to Subpart C, the administrative law judge shall issue a decision (including reasons) based on the application, the supporting documentation, the staff recommendation, the public comments and the evidence submitted during the hearing (the record), stating whether it has been demonstrated, based on a preponderance of evidence, that the applicant meets the requirements for recognition. If no exceptions are filed, this is the final decision of the Department of Labor.
    - (3) Upon issuance of the decision, any party to the hearing may file exceptions within 20 days pursuant to subpart C. If exceptions are filed, the administrative law judge shall forward the decision, exceptions and record to the assistant secretary for the final decision on the application.
    - (4) The Assistant Secretary shall review the record, the decision by the administrative law judge, and the exceptions. based on this, the assistant secretary shall issue the final decision (including reasons) of the department of labor stating whether the applicant has demonstrated by a preponderance of evidence that it meets the requirements for recognition.
  - c. Publication. a notification of the final decision shall be published in the FEDERAL REGISTER.

#### C. Terms and Conditions of Recognition, Renewal and Revocation

1. The following terms and conditions shall be part of every recognition:
  - a. The recognition of any validation organization will be evidenced by a letter of recognition from OSHA. the letter will provide the specific details of the scope of the OSHA recognition as well as any conditions imposed by OSHA, including any Federal monitoring requirements.
  - b. The recognition of each validation organization will be valid for five years, unless terminated before or renewed after the expiration of the period. The dates of the period of recognition will be stated in the recognition letter.
  - c. The recognized validation organization shall continue to satisfy all the requirements of this appendix and the letter of recognition during the period of recognition.
2. A recognized validation organization may change a test method of the PSDI safety system certification/validation program by notifying the Assistant Secretary of the change, certifying that the revised method will be at least as effective as the prior method, and providing the supporting data upon which its conclusions are based.
3. A recognized validation organization may renew its recognition by filing a renewal request at the address in paragraph I.A.3. of this Appendix, above, not less than 180 calendar days, nor more than one year, before the expiration date of its current recognition. When a recognized validation organization has filed such a renewal request, its current recognition will not expire until a final decision has been made on the request. The renewal request will be processed in accordance with subsection I.B. of this Appendix, above, except that a reinspection is not required but may be performed by OSHA. A hearing will be granted to an objecting member of the public if evidence of failure to meet the requirements of this Appendix is supplied to OSHA.

4. A recognized validation organization may apply to OSHA for an expansion of its current recognition to cover other categories of PSDI certification/validation in addition to those included in the current recognition. The application for expansion will be acted upon and processed by OSHA in accordance with subsection I.B. of this Appendix, subject to the possible reinspection exception. If the validation organization has been recognized for more than one year, meets the requirements for expansion of recognition, and there is no evidence that the recognized validation organization has not been following the requirements of this Appendix and the letter of recognition, an expansion will normally be granted. A hearing will be granted to an objecting member of the public only if evidence of failure to meet the requirements of this Appendix is supplied to OSHA.

5. A recognized validation organization may voluntarily terminate its recognition, either in its entirety or with respect to any area covered in its recognition, by giving written notice to OSHA at any time. The written notice shall indicate the termination date. A validation organization may not terminate its installation certification and recertification validation functions earlier than either one year from the date of the written notice, or the date on which another recognized validation organization is able to perform the validation of installation certification and recertification.

6. a. OSHA may revoke its recognition of a validation organization if its program either has failed to continue to satisfy the requirements of this Appendix or its letter of recognition, has not been performing the validation functions required by the PSDI standard and Appendix A, or has misrepresented itself in its applications. Before proposing to revoke recognition, the Agency will notify the recognized validation organization of the basis of the proposed revocation and will allow rebuttal or correction of the alleged deficiencies. If the deficiencies are not corrected, OSHA may revoke recognition, effective in 60 days, unless the validation organization requests a hearing within that time.
- b. If a hearing is requested, it shall be held before an administrative law judge of the Department of Labor pursuant to the rules specified in 29 CFR Part 1905, Subpart C.
- c. The parties shall be OSHA and the recognized validation organization. The decision shall be made pursuant to the procedures specified in paragraphs I.B.8.b.(2) through (4) of this Appendix except that the burden of proof shall be on OSHA to demonstrate by a preponderance of the evidence that the recognition should be revoked because the validation organization either is not meeting the requirements for recognition, has not been performing the validation functions required by the PSDI standard and Appendix A, or has misrepresented itself in its applications.

#### D. Provisions of OSHA Recognition

Each recognized third-party validation organization and its validating laboratories shall:

1. Allow OSHA to conduct unscheduled reviews or on-site audits of it or the validating laboratories on matters relevant to PSDI, and cooperate in the conduct of these reviews and audits;
2. Agree to terms and conditions established by OSHA in the grant of recognition on matters such as exchange of data, submission of accident reports, and assistance in studies for improving PSDI or the certification/validation process.

#### II. Qualifications

The third-party validation organization, the validating laboratory, and the employees of each shall meet the requirements set forth in this section of this Appendix.

##### A. Experience of Validation Organization

1. The third-party validation organization shall have legal authority to perform certification/validation activities.
2. The validation organization shall demonstrate competence and experience in either power press design, manufacture or use, or testing, quality control or certification/validation of equipment comparable to power presses and associated control systems.
3. The validation organization shall demonstrate a capability for selecting, reviewing, and/or validating appropriate standards and test methods to be used for validating the certification of PSDI safety

systems, as well as for reviewing judgements on the safety of PSDI safety systems and their conformance with the requirements of this section.

4. The validating organization may utilize the competence, experience, and capability of its employees to demonstrate this competence, experience and capability.

#### B. Independence of Validation Organization

1. The validation organization shall demonstrate that:
  - a. It is financially capable to conduct the work;
  - b. It is free of direct influence or control by manufacturers, suppliers, vendors, representatives of employers and employees, and employer or employee organizations; and
  - c. Its employees are secure from discharge resulting from pressures from manufacturers, suppliers, vendors, employers or employee representatives.
2. A validation organization may be considered independent even if it has ties with manufacturers, employers or employee representatives if these ties are with at least two of these three groups; it has a board of directors (or equivalent leadership responsibilities for the certification/validation activities) which includes representatives of the three groups; and it has a binding commitment of funding for a period of three years or more.

#### C. Validating Laboratory

The validation organization's laboratory (which organizationally may be a part of the third-party validation organization):

1. Shall have legal authority to perform the validation of certification;
2. Shall be free of operational control and influence of manufacturers, suppliers, vendors, employers, or employee representatives that would impair its integrity of performance; and
3. Shall not engage in the design, manufacture, sale, promotion, or use of the certified equipment.

#### D. Facilities and Equipment

The validation organization's validating laboratory shall have available all testing facilities and necessary test and inspection equipment relevant to the validation of the certification of PSDI safety systems, installations and operations.

#### E. Personnel

The validation organization and the validating laboratory shall be adequately staffed by personnel who are qualified by technical training and/or experience to conduct the validation of the certification of PSDI safety systems.

1. The validation organization shall assign overall responsibility for the validation of PSDI certification to an Administrative Director. Minimum requirements for this position are a Bachelor's degree and five years professional experience, at least one of which shall have been in responsible charge of a function in the areas of power press design or manufacture or a broad range of power press use, or in the areas of testing, quality control, or certification/validation of equipment comparable to power presses or their associated control systems.
2. The validating laboratory, if a separate organization from the validation organization, shall assign technical responsibility for the validation of PSDI certification to a Technical Director. Minimum requirements for this position are a Bachelor's degree in a technical field and five years of professional experience, at least one of which shall have been in responsible charge of a function in the area of testing, quality control or certification/validation of equipment comparable to power presses or their associated control systems.
3. If the validation organization and the validating laboratory are the same organization, the administrative and technical responsibilities may be combined in a single position, with minimum requirements as described in E.1. and 2. for the combined position.
4. The validation organization and validating laboratory shall have adequate administrative and technical staffs to conduct the validation of the certification of PSDI safety systems.

#### F. Certification/Validation Mark or Logo

1. The validation organization or the validating laboratory shall own a registered certification/validation mark or logo.
2. The mark or logo shall be suitable for incorporation into the label required by paragraph (h)(11)(iii) of this section.

### III. Program Requirements

#### A. Test and Certification/Validation Procedures

1. The validation organization and/or validating laboratory shall have established written procedures for test and certification/validation of PSDI safety systems. The procedures shall be based on pertinent OSHA standards and test methods, or other publicly available standards and test methods generally recognized as appropriate in the field, such as national consensus standards or published standards of professional societies or trade associations.
2. The written procedures for test and certification/validation of PSDI systems, and the standards and test methods on which they are based, shall be reproducible and be available to OSHA and to the public upon request.

#### B. Test Reports

1. A test report shall be prepared for each PSDI safety system that is tested. The test report shall be signed by a technical staff representative and the Technical Director.
2. The test report shall include the following:
  - a. Name of manufacturer and catalog or model number of each subsystem or major component.
  - b. Identification and description of test methods or procedures used. (This may be through reference to published sources which describe the test methods or procedures used.)
  - c. Results of all tests performed.
  - d. All safety distance calculations.
3. A copy of the test report shall be maintained on file at the validation organization and/or validating laboratory, and shall be available to OSHA upon request.

#### C. Certification/Validation Reports

1. A certification/validation report shall be prepared for each PSDI safety system for which the certification is validated. The certification/validation report shall be signed by the Administrative Director and the Technical Director.
2. The certification/validation report shall include the following:
  - a. Name of manufacturer and catalog or model number of each subsystem or major component.
  - b. Results of all tests which serve as the basis for the certification.
  - c. All safety distance calculations.
  - d. Statement that the safety system conforms with all requirements of the PSDI standard and Appendix A.
3. A copy of the certification/validation report shall be maintained on file at the validation organization and/or validating laboratory, and shall be available to the public upon request.
4. A copy of the certification/validation report shall be submitted to OSHA within 30 days of its completion.

#### D. Publications System

The validation organization shall make available upon request a list of PSDI safety systems which have been certified/validated by the program.

#### E. Follow-up Activities

1. The validation organization or validating laboratory shall have a follow-up system for inspecting or testing manufacturer's production of design certified/validated PSDI safety system components and subassemblies where deemed appropriate by the validation organization.
2. The validation organization shall notify the appropriate product manufacturer(s) of any reports from employers of point of operation injuries which occur while a press is operated in a PSDI mode.

#### F. Records

The validation organization or validating laboratory shall maintain a record of each certification/validation of a PSDI safety system, including manufacturer and/or employer certification documentation, test and working data, test report, certification/validation report, any follow-up inspections or testing, and reports of equipment failures, any reports of accidents involving the equipment, and any other pertinent information. These records shall be available for inspection by OSHA and OSHA State Plan offices.

#### G. Dispute Resolution Procedures

1. The validation organization shall have a reasonable written procedure for acknowledging and processing appeals or complaints from program participants (manufacturers, producers, suppliers, vendors and employers) as well as other interested parties (employees or their representatives, safety personnel, government agencies, etc.), concerning certification or validation.
2. The validation organization may charge any complainant the reasonable charge for repeating tests needed for the resolution of disputes.

### **APPENDIX D TO §1910.217--NONMANDATORY SUPPLEMENTARY INFORMATION**

This Appendix provides nonmandatory supplementary information and guidelines to assist in the understanding and use of 29 CFR 1910.217(h) to allow presence sensing device initiation (PSDI) of mechanical power presses. Although this Appendix as such is not mandatory, it references sections and requirements which are made mandatory by other parts of the PSDI standard and appendices.

#### 1. General

OSHA intends that PSDI continue to be prohibited where present state-of-the-art technology will not allow it to be done safely. Only part revolution type mechanical power presses are approved for PSDI. Similarly, only presses with a configuration such that a person's body cannot completely enter the bed area are approved for PSDI.

#### 2. Brake and Clutch

Flexible steel band brakes do not possess a long-term reliability against structural failure as compared to other types of brakes, and therefore are not acceptable on presses used in the PSDI mode of operation.

Fast and consistent stopping times are important to safety for the PSDI mode of operation. Consistency of braking action is enhanced by high brake torque. The requirement in paragraph (h)(2)(ii) defines a high torque capability which should ensure fast and consistent stopping times.

Brake design parameters important to PSDI are high torque, low moment of inertia, low air volume (if pneumatic) mechanisms, non-interleaving engagement springs, and structural integrity which is enhanced

by over-design. The requirement in paragraph (h)(2)(iii) reduces the possibility of significantly increased stopping time if a spring breaks.

As an added precaution to the requirements in paragraph (h)(2)(iii), brake adjustment locking means should be secured. Where brake springs are externally accessible, lock nuts or other means may be provided to reduce the possibility of backing off of the compression nut which holds the springs in place.

### 3. Pneumatic Systems

Elevated clutch/brake air pressure results in longer stopping time. The requirement in paragraph (h)(3)(i)(C) is intended to prevent degradation in stopping speed from higher air pressure. Higher pressures may be permitted, however, to increase clutch torque to free "jammed" dies, provided positive measures are provided to prevent the higher pressure at other times.

### 4. Flywheels and Bearings

Lubrication of bearings is considered the single greatest deterrent to their failure. The manufacturer's recommended procedures for maintenance and inspection should be closely followed.

### 5. Brake Monitoring

The approval of brake monitor adjustments, as required in paragraph (h)(5)(ii), is not considered a recertification, and does not necessarily involve an on-site inspection by a representative of the validation organization. It is expected that the brake monitor adjustment normally could be evaluated on the basis of the effect on the safety system certification/validation documentation retained by the validation organization.

Use of a brake monitor does not eliminate the need for periodic brake inspection and maintenance to reduce the possibility of catastrophic failures.

### 6. Cycle Control and Control Systems

The PSDI set-up/reset means required by paragraph (h)(6)(iv) may be initiated by the actuation of a special momentary pushbutton or by the actuation of a special momentary pushbutton and the initiation of a first stroke with two hand controls.

It would normally be preferable to limit the adjustment of the time required in paragraph (h)(6)(vi) to a maximum of 15 seconds. However, where an operator must do many operations outside the press, such as lubricating, trimming, deburring, etc., a longer interval up to 30 seconds is permitted.

When a press is equipped for PSDI operation, it is recommended that the presence sensing device be active as a guarding device in other production modes. This should enhance the reliability of the device and ensure that it remains operable. An acceptable method for interlocking supplemental guards as required by paragraph (h)(6)(xiii) would be to incorporate the supplemental guard and the PSDI presence sensing device into a hinged arrangement in which the alignment of the presence sensing device serves, in effect, as the interlock. If the supplemental guards are moved, the presence sensing device would become misaligned and the press control would be deactivated. No extra micro switches or interlocking sensors would be required. Paragraph (h)(6)(xv) of the standard requires that the control system have provisions for an "inch" operating means; that die-setting not be done in the PSDI mode; and that production not be done in the "inch" mode. It should be noted that the sensing device would be by-passed in the "inch" mode. For that reason, the prohibitions against die-setting in the PSDI mode, and against production in the "inch" mode are cited to emphasize that "inch" operation is of reduced safety and is not compatible with PSDI or other production modes.

### 7. Environmental Requirements

It is the intent of paragraph (h)(7) that control components be provided with inherent design protection against operating stresses and environmental factors affecting safety and reliability.

### 8. Safety System

The safety system provision continues the concept of paragraph (b)(13) that the probability of two independent failures in the length of time required to make one press cycle is so remote as to be a negligible risk factor in the total array of equipment and human factors. The emphasis is on an integrated total system including all elements affecting point of operation safety.

It should be noted that this does not require redundancy for press components such as structural elements, clutch/brake mechanisms, plates, etc., for which adequate reliability may be achieved by proper design, maintenance, and inspection.

## 9. Safeguarding the Point of Operation

The intent of paragraph (h)(9)(iii) is to prohibit use of mirrors to "bend" a single light curtain sensing field around corners to cover more than one side of a press. This prohibition is needed to increase the reliability of the presence sensing device in initiating a stroke only when the desired work motion has been completed. "Object sensitivity" describes the capability of a presence sensing device to detect an object in the sensing field, expressed as the linear measurement of the smallest interruption which can be detected at any point in the field. Minimum object sensitivity describes the largest acceptable size of the interruption in the sensing field. A minimum object sensitivity of one and one fourth inches (31.75 mm) means that a one and one-fourth inch (31.75 mm) diameter object will be continuously detected at all locations in the sensing field.

In deriving the safety distance required in paragraph (h)(9)(v), all stopping time measurements should be made with clutch/brake air pressure regulated to the press manufacturer's recommended value for full clutch torque capability. The stopping time measurements should be made with the heaviest upper die that is planned for use in the press. If the press has a slide counterbalance system, it is important that the counterbalance be adjusted correctly for upper die weight according to the manufacturer's instructions. While the brake monitor setting is based on the stopping time it actually measures, i.e., the normal stopping time at the top of the stroke, it is important that the safety distance be computed from the longest stopping time measured at any of the indicated three downstroke stopping positions listed in the explanation of  $T_s$ . The use in the formula of twice the stopping time increase,  $T_m$ , allowed by the brake monitor for brake wear allows for greater increases in the downstroke stopping time than occur in normal stopping time at the top of the stroke.

## 10. Inspection and Maintenance. [Reserved]

## 11. Safety System Certification/Validation

Mandatory requirements for certification/validation of the PSDI safety system are provided in Appendix A and Appendix C to this standard. Nonmandatory supplementary information and guidelines relating to certification/validation of the PSDI safety system are provided to Appendix B to this standard.

### §1910.218 Forging machines.

#### (a) General requirements.

- (1) Use of lead. The safety requirements of this subparagraph apply to lead casts or other use of lead in the forge shop or die shop.
  - (i) Thermostatic control of heating elements shall be provided to maintain proper melting temperature and prevent overheating.
  - (ii) Fixed or permanent lead pot installations shall be exhausted.
  - (iii) Portable units shall be used only in areas where good, general room ventilation is provided.
  - (iv) Personal protective equipment (gloves, goggles, aprons, and other items) shall be worn.
  - (v) A covered container shall be provided to store dross skimmings.
  - (vi) Equipment shall be kept clean, particularly from accumulations of yellow lead oxide.
- (2) Inspection and maintenance. It shall be the responsibility of the employer to maintain all forge shop equipment in a condition which will insure continued safe operation. This responsibility includes:
  - (i) Establishing periodic and regular maintenance safety checks and keeping certification records of these inspections which include the date of inspection, the signature of the

- person who performed the inspection and the serial number, or other identifier, for the forging machine which was inspected.
- (ii) Scheduling and recording the inspection of guards and point of operation protection devices at frequent and regular intervals. Recording of inspections shall be in the form of a certification record which includes the date the inspection was performed, the signature of the person who performed the inspection and the serial number, or other identifier, of the equipment inspected.
- (iii) Training personnel for the proper inspection and maintenance of forging machinery and equipment.
- (iv) All overhead parts shall be fastened or protected in such a manner that they will not fly off or fall in event of failure.
- (3) Hammers and presses.
  - (i) All hammers shall be positioned or installed in such a manner that they remain on or are anchored to foundations sufficient to support them according to applicable engineering standards.
  - (ii) All presses shall be installed in such a manner that they remain where they are positioned or they are anchored to foundations sufficient to support them according to applicable engineering standards.

TABLE O-11--STRENGTH AND DIMENSIONS FOR WOOD RAM PROPS

| Size of timber, inches <sup>1</sup> | Square inches in cross section | Minimum allowable crushing strength parallel to grain, p.s.i. <sup>2</sup> | Maximum static load within short column range <sup>3</sup> | Safety factor | Maximum recommended weight of forging hammer for timber used | Maximum allowable length of timber, inches |
|-------------------------------------|--------------------------------|----------------------------------------------------------------------------|------------------------------------------------------------|---------------|--------------------------------------------------------------|--------------------------------------------|
| 4 x 4                               | 16                             | 5,000                                                                      | 80,000                                                     | 10            | 8,000                                                        | 44                                         |
| 6 x 6                               | 36                             | 5,000                                                                      | 180,000                                                    | 10            | 18,000                                                       | 66                                         |
| 8 x 8                               | 64                             | 5,000                                                                      | 320,000                                                    | 10            | 32,000                                                       | 88                                         |
| 10 x 10                             | 100                            | 5,000                                                                      | 500,000                                                    | 10            | 50,000                                                       | 100                                        |
| 12 x 12                             | 144                            | 5,000                                                                      | 720,000                                                    | 10            | 72,000                                                       | 132                                        |

<sup>1</sup>Actual dimension.

<sup>2</sup>Adapted from U.S. Department of Agriculture Technical Bulletin 479. Hardwoods recommended are those whose ultimate crushing strengths in compression parallel to grain are 5,000 p.s.i. (pounds per square inch) or greater.

<sup>3</sup>Slenderness ratio formula for short columns is  $L/d=11$ , where L=length of timber in inches and d=least dimension in inches; this ratio should not exceed 11.

- (iii) Means shall be provided for disconnecting the power to the machine and for locking out or rendering cycling controls inoperable.
  - (iv) The ram shall be blocked when dies are being changed or other work is being done on the hammer. Blocks or wedges shall be made of material the strength and construction of which should meet or exceed the specifications and dimensions shown in Table O-11.
  - (v) Tongs shall be of sufficient length to clear the body of the worker in case of kickback, and shall not have sharp handle ends.
  - (vi) Oil swabs, or scale removers, or other devices to remove scale shall be provided. These devices shall be long enough to enable a man to reach the full length of the die without placing his hand or arm between the dies.
  - (vii) Material handling equipment shall be of adequate strength, size, and dimension to handle diesetting operations safely.
  - (viii) A scale guard of substantial construction shall be provided at the back of every hammer, so arranged as to stop flying scale.
  - (ix) A scale guard of substantial construction shall be provided at the back of every press, so arranged as to stop flying scale.
- (b) Hammers, general.

- (1) Keys. Die keys and shims shall be made from a grade of material that will not unduly crack or splinter.
- (2) Foot operated devices. All foot operated devices (i.e., treadles, pedals, bars, valves, and switches) shall be substantially and effectively protected from unintended operation.
- (c) Presses. All manually operated valves and switches shall be clearly identified and readily accessible.
- (d) Power-driven hammers.
  - (1) Safety cylinder head. Every steam or airhammer shall have a safety cylinder head to act as a cushion if the rod should break or pullout of the ram.
  - (2) Shutoff valve. Steam hammers shall be provided with a quick closing emergency valve in the admission pipeline at a convenient location. This valve shall be closed and locked in the off position while the hammer is being adjusted, repaired, or serviced, or when the dies are being changed.
  - (3) Cylinder draining. Steam hammers shall be provided with a means of cylinder draining, such as a self-draining arrangement or a quick-acting drain cock.
  - (4) Pressure pipes. Steam or air piping shall conform to the specifications of American National Standard ANSI B31.1.0-1967, Power Piping with Addenda issued before April 28, 1971, which is incorporated by reference as specified in §1910.6.
- (e) Gravity hammers.
  - (1) Air-lift hammers.
    - (i) Air-lift hammers shall have a safety cylinder head as required in paragraph (d)(1) of this section.
    - (ii) Air-lift hammers shall have an air shutoff valve as required in paragraph (d)(2) of this section.
    - (iii) Air-lift hammers shall be provided with two drain cocks: one on main head cylinder, and one on clamp cylinder.
    - (iv) Air piping shall conform to the specifications of the ANSI B31.1.0-1967, Power Piping with Addenda issued before April 28, 1971, which is incorporated by reference as specified in §1910.6.
  - (2) Board drophammers.
    - (i) A suitable enclosure shall be provided to prevent damaged or detached boards from falling. The board enclosure shall be securely fastened to the hammer.
    - (ii) All major assemblies and fittings which can loosen and fall shall be properly secured in place.
- (f) Forging presses.
  - (1) Mechanical forging presses. When dies are being changed or maintenance is being performed on the press, the following shall be accomplished:
    - (i) The power to the press shall be locked out.
    - (ii) The flywheel shall be at rest.
    - (iii) The ram shall be blocked with a material the strength of which shall meet or exceed the specifications or dimensions shown in Table O-11.
  - (2) Hydraulic forging presses. When dies are being changed or maintenance is being performed on the press, the following shall be accomplished:
    - (i) The hydraulic pumps and power apparatus shall be locked out.
    - (ii) The ram shall be blocked with a material the strength of which shall meet or exceed the specifications or dimensions shown in Table O-11.
- (g) Trimming presses.
  - (1) Hot trimming presses. The requirements of paragraph (f)(1) of this section shall also apply to hot trimming presses.
  - (2) Cold trimming presses. Cold trimming presses shall be safeguarded in accordance with §1910.217(c).
- (h) Upsetters.
  - (1) General requirements. All upsetters shall be installed so that they remain on their supporting foundations.
  - (2) Lockouts. Upsetters shall be provided with a means for locking out the power at its entry point to the machine and rendering its cycling controls inoperable.
  - (3) Manually operated controls. All manually operated valves and switches shall be clearly identified

and readily accessible.

- (4) Tongs. Tongs shall be of sufficient length to clear the body of the worker in case of kickback, and shall not have sharp handle ends.
- (5) Changing dies. When dies are being changed, maintenance performed, or any work done on the machine, the power to the upsetter shall be locked out, and the flywheel shall be at rest.
- (i) Other forging equipment.
  - (1) Boltheadings. The provisions of paragraph (h) of this section shall apply to boltheadings.
  - (2) Rivet making. The provisions of paragraph (h) of this section shall apply to rivet making.
- (j) Other forge facility equipment.
  - (1) Billet shears. A positive-type lockout device for disconnecting the power to the shear shall be provided.
  - (2) Saws. Every saw shall be provided with a guard of not less than one-eighth inch sheet metal positioned to stop flying sparks.
  - (3) Conveyors. Conveyor power transmission equipment shall be guarded in accordance with ANSI B20.1-1957, Safety Code for Conveyors, Cableways, and Related Equipment, which is incorporated by reference as specified in §1910.6.
  - (4) Shot blast. The cleaning chamber shall have doors or guards to protect operators.
  - (5) Grinding. Personal protective equipment shall be used in grinding operations, and equipment shall be used and maintained in accordance with ANSI B7.1-1970, Safety Code for the Use, Care, and Protection of Abrasive Wheels, which is incorporated by reference as specified in §1910.6, and with §1910.215.

**§1910.219 Mechanical power-transmission apparatus.**

**(a) General requirements.**

- (1) This section covers all types and shapes of power-transmission belts, except the following when operating at two hundred and fifty (250) feet per minute or less: (i) Flat belts one (1) inch or less in width, (ii) flat belts two (2) inches or less in width which are free from metal lacings or fasteners, (iii) round belts one-half (1/2) inch or less in diameter; and (iv) single strand V-belts, the width of which is thirteen thirty-seconds (13/32) inch or less.
- (2) Vertical and inclined belts (paragraphs (e) (3) and (4) of this section) if not more than two and one-half (2 1/2) inches wide and running at a speed of less than one thousand (1,000) feet per minute, and if free from metal lacings or fastenings may be guarded with a nip-point belt and pulley guard.
- (3) For the Textile Industry, because of the presence of excessive deposits of lint, which constitute a serious fire hazard, the sides and face sections only of nip-point belt and pulley guards are required, provided the guard shall extend at least six (6) inches beyond the rim of the pulley on the in-running and off-running sides of the belt and at least two (2) inches away from the rim and face of the pulley in all other directions.
- (4) This section covers the principal features with which power transmission safeguards shall comply.

**(b) Prime-mover guards.**

- (1) Flywheels. Flywheels located so that any part is seven (7) feet or less above floor or platform shall be guarded in accordance with the requirements of this subparagraph:
  - (i) With an enclosure of sheet, perforated, or expanded metal, or woven wire;
  - (ii) With guard rails placed not less than fifteen (15) inches nor more than twenty (20) inches from rim. When flywheel extends into pit or is within 12 inches of floor, a standard toeboard shall also be provided;
  - (iii) When the upper rim of flywheel protrudes through a working floor, it shall be entirely enclosed or surrounded by a guardrail and toeboard.
  - (iv) For flywheels with smooth rims five (5) feet or less in diameter, where the preceding methods cannot be applied, the following may be used: A disk attached to the flywheel in such manner as to cover the spokes of the wheel on the exposed side and present a smooth surface and edge, at the same time providing means for periodic inspection. An open space, not exceeding four (4) inches in width, may be left between the outside edge of the disk and the rim of the wheel if desired, to facilitate turning the wheel over. Where a disk

is used, the keys or other dangerous projections not covered by disk shall be cut off or covered. This subdivision does not apply to flywheels with solid web centers.

- (v) Adjustable guard to be used for starting engine or for running adjustment may be provided at the flywheel of gas or oil engines. A slot opening for jack bar will be permitted.
  - (vi) Wherever flywheels are above working areas, guards shall be installed having sufficient strength to hold the weight of the flywheel in the event of a shaft or wheel mounting failure.
- (2) Cranks and connecting rods. Cranks and connecting rods, when exposed to contact, shall be guarded in accordance with paragraphs (m) and (n) of this section, or by a guardrail as described in paragraph (o)(5) of this section.
  - (3) Tail rods or extension piston rods. Tail rods or extension piston rods shall be guarded in accordance with paragraphs (m) and (o) of this section, or by a guardrail on sides and end, with a clearance of not less than fifteen (15) nor more than twenty (20) inches when rod is fully extended.
- (c) Shafting.**
- (1) Installation.
    - (i) Each continuous line of shafting shall be secured in position against excessive endwise movement.
    - (ii) Inclined and vertical shafts, particularly inclined idler shafts, shall be securely held in position against endwise thrust.
  - (2) Guarding horizontal shafting.
    - (i) All exposed parts of horizontal shafting seven (7) feet or less from floor or working platform, excepting runways used exclusively for oiling, or running adjustments, shall be protected by a stationary casing enclosing shafting completely or by a trough enclosing sides and top or sides and bottom of shafting as location requires.
    - (ii) Shafting under bench machines shall be enclosed by a stationary casing, or by a trough at sides and top or sides and bottom, as location requires. The sides of the trough shall come within at least six (6) inches of the underside of table, or if shafting is located near floor within six (6) inches of floor. In every case the sides of trough shall extend at least two (2) inches beyond the shafting or protuberance.
  - (3) Guarding vertical and inclined shafting. Vertical and inclined shafting seven (7) feet or less from floor or working platform, excepting maintenance runways, shall be enclosed with a stationary casing in accordance with requirements of paragraphs (m) and (o) of this section.
  - (4) Projecting shaft ends.
    - (i) Projecting shaft ends shall present a smooth edge and end and shall not project more than one-half the diameter of the shaft unless guarded by nonrotating caps or safety sleeves.
    - (ii) Unused keyways shall be filled up or covered.
  - (5) Power-transmission apparatus located in basements. All mechanical power transmission apparatus located in basements, towers, and rooms used exclusively for power transmission equipment shall be guarded in accordance with this section, except that the requirements for safeguarding belts, pulleys, and shafting need not be complied with when the following requirements are met:
    - (i) The basement, tower, or room occupied by transmission equipment is locked against unauthorized entrance.
    - (ii) The vertical clearance in passageways between the floor and power transmission beams, ceiling, or any other objects, is not less than five feet six inches (5 ft. 6 in.).
    - (iii) The intensity of illumination conforms to the requirements of ANSI A11.1-1965 (R-1970), which is incorporated by reference as specified in §1910.6.
    - (iv) [Reserved]
    - (v) The route followed by the oiler is protected in such manner as to prevent accident.
- (d) Pulleys.**
- (1) Guarding. Pulleys, any parts of which are seven (7) feet or less from the floor or working platform, shall be guarded in accordance with the standards specified in paragraphs (m) and (o) of this section. Pulleys serving as balance wheels (e.g., punch presses) on which the point of contact between belt and pulley is more than six feet six inches (6 ft. 6 in.) from the floor or platform may be guarded with a disk covering the spokes.
  - (2) Location of pulleys.

- (i) Unless the distance to the nearest fixed pulley, clutch, or hanger exceeds the width of the belt used, a guide shall be provided to prevent the belt from leaving the pulley on the side where insufficient clearance exists.
- (ii) [Reserved]
- (3) Broken pulleys. Pulleys with cracks, or pieces broken out of rims, shall not be used.
- (4) Pulley speeds. Pulleys intended to operate at rim speed in excess of manufacturers normal recommendations shall be specially designed and carefully balanced for the speed at which they are to operate.
- (e) Belt, rope, and chain drives.
  - (1) Horizontal belts and ropes.
    - (i) Where both runs of horizontal belts are seven (7) feet or less from the floor level, the guard shall extend to at least fifteen (15) inches above the belt or to a standard height (see Table O-12), except that where both runs of a horizontal belt are 42 inches or less from the floor, the belt shall be fully enclosed in accordance with paragraphs (m) and (o) of this section.
    - (ii) In powerplants or power-development rooms, a guardrail may be used in lieu of the guard required by subdivision (i) of this subparagraph.
  - (2) Overhead horizontal belts.
    - (i) Overhead horizontal belts, with lower parts seven (7) feet or less from the floor or platform, shall be guarded on sides and bottom in accordance with paragraph (o)(3) of this section.
    - (ii) Horizontal overhead belts more than seven (7) feet above floor or platform shall be guarded for their entire length under the following conditions:
      - (a) If located over passageways or work places and traveling 1,800 feet or more per minute.
      - (b) If center to center distance between pulleys is ten (10) feet or more.
      - (c) If belt is eight (8) inches or more in width.
    - (iii) Where the upper and lower runs of horizontal belts are so located that passage of persons between them would be possible, the passage shall be either:
      - (a) Completely barred by a guardrail or other barrier in accordance with paragraphs (m) and (o) of this section; or
      - (b) Where passage is regarded as necessary, there shall be a platform over the lower run guarded on either side by a railing completely filled in with wire mesh or other filler, or by a solid barrier. The upper run shall be so guarded as to prevent contact therewith either by the worker or by objects carried by him. In powerplants only the lower run of the belt need be guarded.
    - (iv) Overhead chain and link belt drives are governed by the same rules as overhead horizontal belts and shall be guarded in the same manner as belts.
  - (3) Vertical and inclined belts.
    - (i) Vertical and inclined belts shall be enclosed by a guard conforming to standards in paragraphs (m) and (o) of this section.
    - (ii) All guards for inclined belts shall be arranged in such a manner that a minimum clearance of seven (7) feet is maintained between belt and floor at any point outside of guard.
  - (4) Vertical belts. Vertical belts running over a lower pulley more than seven (7) feet above floor or platform shall be guarded at the bottom in the same manner as horizontal overhead belts, if conditions are as stated in paragraphs (e)(2)(ii) (a) and (c) of this section.
  - (5) Cone-pulley belts.
    - (i) The cone belt and pulley shall be equipped with a belt shifter so constructed as to adequately guard the nip point of the belt and pulley. If the frame of the belt shifter does not adequately guard the nip point of the belt and pulley, the nip point shall be further protected by means of a vertical guard placed in front of the pulley and extending at least to the top of the largest step of the cone.
    - (ii) If the belt is of the endless type or laced with rawhide laces, and a belt shifter is not desired, the belt will be considered guarded if the nip point of the belt and pulley is protected by a nip point guard located in front of the cone extending at least to the top of the largest step of the cone, and formed to show the contour of the cone in order to give the nip point of the belt and pulley the maximum protection.

- (iii) If the cone is located less than 3 feet from the floor or working platform, the cone pulley and belt shall be guarded to a height of 3 feet regardless of whether the belt is endless or laced with rawhide.
- (6) Belt tighteners.
  - (i) Suspended counterbalanced tighteners and all parts thereof shall be of substantial construction and securely fastened; the bearings shall be securely capped. Means must be provided to prevent tightener from falling, in case the belt breaks.
  - (ii) Where suspended counterweights are used and not guarded by location, they shall be so encased as to prevent accident.
- (f)** Gears, sprockets, and chains.
  - (1) Gears. Gears shall be guarded in accordance with one of the following methods:
    - (i) By a complete enclosure; or
    - (ii) By a standard guard as described in paragraph (o) of this section, at least seven (7) feet high extending six (6) inches above the mesh point of the gears; or
    - (iii) By a band guard covering the face of gear and having flanges extended inward beyond the root of the teeth on the exposed side or sides. Where any portion of the train of gears guarded by a band guard is less than six (6) feet from the floor a disk guard or a complete enclosure to the height of six (6) feet shall be required.
  - (2) Hand-operated gears. Paragraph (f)(1) of this section does not apply to hand-operated gears used only to adjust machine parts and which do not continue to move after hand power is removed. However, the guarding of these gears is highly recommended.
  - (3) Sprockets and chains. All sprocket wheels and chains shall be enclosed unless they are more than seven (7) feet above the floor or platform. Where the drive extends over other machine or working areas, protection against falling shall be provided. This subparagraph does not apply to manually operated sprockets.
  - (4) Openings for oiling. When frequent oiling must be done, openings with hinged or sliding self-closing covers shall be provided. All points not readily accessible shall have oil feed tubes if lubricant is to be added while machinery is in motion.
- (g)** Guarding friction drives. The driving point of all friction drives when exposed to contact shall be guarded, all arm or spoke friction drives and all web friction drives with holes in the web shall be entirely enclosed, and all projecting belts on friction drives where exposed to contact shall be guarded.
- (h)** Keys, setscrews, and other projections.
  - (1) All projecting keys, setscrews, and other projections in revolving parts shall be removed or made flush or guarded by metal cover. This subparagraph does not apply to keys or setscrews within gear or sprocket casings or other enclosures, nor to keys, setscrews, or oilcups in hubs of pulleys less than twenty (20) inches in diameter where they are within the plane of the rim of the pulley.
  - (2) It is recommended, however, that no projecting setscrews or oilcups be used in any revolving pulley or part of machinery.
- (i)** Collars and couplings.
  - (1) Collars. All revolving collars, including split collars, shall be cylindrical, and screws or bolts used in collars shall not project beyond the largest periphery of the collar.
  - (2) Couplings. Shaft couplings shall be so constructed as to present no hazard from bolts, nuts, setscrews, or revolving surfaces. Bolts, nuts, and setscrews will, however, be permitted where they are covered with safety sleeves or where they are used parallel with the shafting and are countersunk or else do not extend beyond the flange of the coupling.
- (j)** Bearings and facilities for oiling. All drip cups and pans shall be securely fastened.
- (k)** Guarding of clutches, cutoff couplings, and clutch pulleys.
  - (1) Guards. Clutches, cutoff couplings, or clutch pulleys having projecting parts, where such clutches are located seven (7) feet or less above the floor or working platform, shall be enclosed by a stationary guard constructed in accordance with this section. A "U" type guard is permissible.

- (2) Engine rooms. In engine rooms a guardrail, preferably with toeboard, may be used instead of the guard required by paragraph (k)(1) of this section, provided such a room is occupied only by engine room attendants.
- (l) Belt shifters, clutches, shippers, poles, perches, and fasteners.
  - (1) Belt shifters.
    - (i) Tight and loose pulleys on all new installations made on or after August 31, 1971, shall be equipped with a permanent belt shifter provided with mechanical means to prevent belt from creeping from loose to tight pulley. It is recommended that old installations be changed to conform to this rule.
    - (ii) Belt shifter and clutch handles shall be rounded and be located as far as possible from danger of accidental contact, but within easy reach of the operator. Where belt shifters are not directly located over a machine or bench, the handles shall be cut off six feet six inches (6 ft. 6 in.) above floor level.
  - (2) Belt shippers and shipper poles. The use of belt poles as substitutes for mechanical shifters is not recommended.
  - (3) Belt perches. Where loose pulleys or idlers are not practicable, belt perches in form of brackets, rollers, etc., shall be used to keep idle belts away from the shafts.
  - (4) Belt fasteners. Belts which of necessity must be shifted by hand and belts within seven (7) feet of the floor or working platform which are not guarded in accordance with this section shall not be fastened with metal in any case, nor with any other fastening which by construction or wear will constitute an accident hazard.
- (m) Standard guards-general requirements.
  - (1) Materials.
    - (i) Standard conditions shall be secured by the use of the following materials. Expanded metal, perforated or solid sheet metal, wire mesh on a frame of angle iron, or iron pipe securely fastened to floor or to frame of machine.
    - (ii) All metal should be free from burrs and sharp edges.
  - (2) Methods of manufacture.
    - (i) Expanded metal, sheet or perforated metal, and wire mesh shall be securely fastened to frame.
    - (ii) [Reserved]
- (n) [Reserved]
- (o) Approved materials.
  - (1) Minimum requirements. The materials and dimensions specified in this paragraph shall apply to all guards, except horizontal overhead belts, rope, cable, or chain guards more than seven (7) feet above floor, or platform.
    - (i) [Reserved]
      - (a) All guards shall be rigidly braced every three (3) feet or fractional part of their height to some fixed part of machinery or building structure. Where guard is exposed to contact with moving equipment additional strength may be necessary.
      - (b) [Reserved]
    - (ii) [Reserved]
  - (2) Wood guards.
    - (i) Wood guards may be used in the woodworking and chemical industries, in industries where the presence of fumes or where manufacturing conditions would cause the rapid deterioration of metal guards; also in construction work and in locations outdoors where extreme cold or extreme heat make metal guards and railings undesirable. In all other industries, wood guards shall not be used.
    - (ii) [Reserved]
  - (3) Guards for horizontal overhead belts.
    - (i) Guards for horizontal overhead belts shall run the entire length of the belt and follow the line of the pulley to the ceiling or be carried to the nearest wall, thus enclosing the belt effectively. Where belts are so located as to make it impracticable to carry the guard to wall or ceiling, construction of guard shall be such as to enclose completely the top and bottom runs of belt and the face of pulleys.

- (ii) [Reserved]
  - (iii) Suitable reinforcement shall be provided for the ceiling rafters or overhead floor beams, where such is necessary, to sustain safely the weight and stress likely to be imposed by the guard. The interior surface of all guards, by which is meant the surface of the guard with which a belt will come in contact, shall be smooth and free from all projections of any character, except where construction demands it; protruding shallow roundhead rivets may be used. Overhead belt guards shall be at least one-quarter wider than belt which they protect, except that this clearance need not in any case exceed six (6) inches on each side. Overhead rope drive and block and roller-chain-drive guards shall be not less than six (6) inches wider than the drive on each side. In overhead silent chain-drive guards where the chain is held from lateral displacement on the sprockets, the side clearances required on drives of twenty (20) inch centers or under shall be not less than one-fourth inch from the nearest moving chain part, and on drives of over twenty (20) inch centers a minimum of one-half inch from the nearest moving chain part.
- (4) Guards for horizontal overhead rope and chain drives. Overhead-rope and chain-drive guard construction shall conform to the rules for overhead-belt guard.
  - (5) Guardrails and toeboards.
    - (i) Guardrail shall be forty-two (42) inches in height, with midrail between top rail and floor.
    - (ii) Posts shall be not more than eight (8) feet apart; they are to be permanent and substantial, smooth, and free from protruding nails, bolts, and splinters. If made of pipe, the post shall be one and one-fourth (1 1/4) inches inside diameter, or larger. If made of metal shapes or bars, their section shall be equal in strength to that of one and one-half (1 1/2) by one and one-half (1 1/2) by three-sixteenths (3/16) inch angle iron. If made of wood, the posts shall be two by four (2 x 4) inches or larger. The upper rail shall be two by four (2 x 4) inches, or two one by four (1 x 4) strips, one at the top and one at the side of posts. The midrail may be one by four (1 x 4) inches or more. Where panels are fitted with expanded metal or wire mesh as noted in Table O-12 the middle rails may be omitted. Where guard is exposed to contact with moving equipment, additional strength may be necessary.
    - (iii) Toeboards shall be four (4) inches or more in height, of wood, metal, or of metal grill not exceeding one (1) inch mesh.
- (p) Care of equipment.**
- (1) General. All power-transmission equipment shall be inspected at intervals not exceeding 60 days and be kept in good working condition at all times.
  - (2) Shafting.
    - (i) Shafting shall be kept in alignment, free from rust and excess oil or grease.
    - (ii) Where explosives, explosive dusts, flammable vapors or flammable liquids exist, the hazard of static sparks from shafting shall be carefully considered.
  - (3) Bearings. Bearings shall be kept in alignment and properly adjusted.
  - (4) Hangers. Hangers shall be inspected to make certain that all supporting bolts and screws are tight and that supports of hanger boxes are adjusted properly.
  - (5) Pulleys.
    - (i) Pulleys shall be kept in proper alignment to prevent belts from running off.
    - (ii) [Reserved]
  - (6) Care of belts.
    - (i) [Reserved]
    - (ii) Inspection shall be made of belts, lacings, and fasteners and such equipment kept in good repair.
  - (7) Lubrication. The regular oilers shall wear tight-fitting clothing. Machinery shall be oiled when not in motion, wherever possible.